

Game Changing Solutions for Solar Cable Management





Product Led, People Powered

Established in 1989, we are the original innovators and manufacturers of wire joining and tensioning devices, as well as anchoring, bracing and suspension systems that have changed the game for many industries.

With our innovative, engineered solutions, we're helping customers in industries including solar, civil, utilities, and construction to overcome their toughest daily challenges, achieving their goals faster and easier.

We are no ordinary business. We do almost everything differently.

100% owned by our employees, we're also committed to changing the game by making a positive impact in our communities around the world. We're a force for good, as certified by B Corp.

Change the Game

1 - 100% employee owned

Our empowering employee ownership model means everyone has skin in the game. Success for our global customers means success for us. We are all shareholders, inspired to design, manufacture, and deliver better solutions.

2 - Game changing innovators

Our vision is to engineer game changing products and systems that make a difference for more global customers. To keep us on track, we hold ourselves accountable to deliver a fifth of all sales from new innovations.

3 - Helping customers do more with less

We solve customers' real-world problems with simplified engineered solutions. Whatever the application, our innovations deliver efficient, sustainable solutions that have a positive impact on global customers' routine tasks.

4 - Vertically integrated

As an award-winning global manufacturer, we create finished Gripple solutions from components we produce in-house, on machinery we design and build ourselves. We're a trusted partner for our customers, able to deliver quality, reliability, and value.

5 - A force for good

It's the Gripple way to do business differently. Not just to deliver profit, but to share the benefits of global sustainable growth with our customers, communities, and employee-owners. As a certified B Corp, we meet the highest standards of social and environmental performance.

Contents

Vertically Integrated Manufacturing	4
Changing the Game in 85 Countries Worldwide	5
Changing the Game in Solar Cable Management	6
Our String Cable Management Solutions	8
String Cable Management	10
Home Run Cable Management Solutions	12
Home Run Cable Management	14
Our Products – Cable Smart Hangers	16
Our Products – CableSmart Messenger System	18
Our Products – Direct Fix Solutions	19
Technical Support	20
Gripple Technology	22

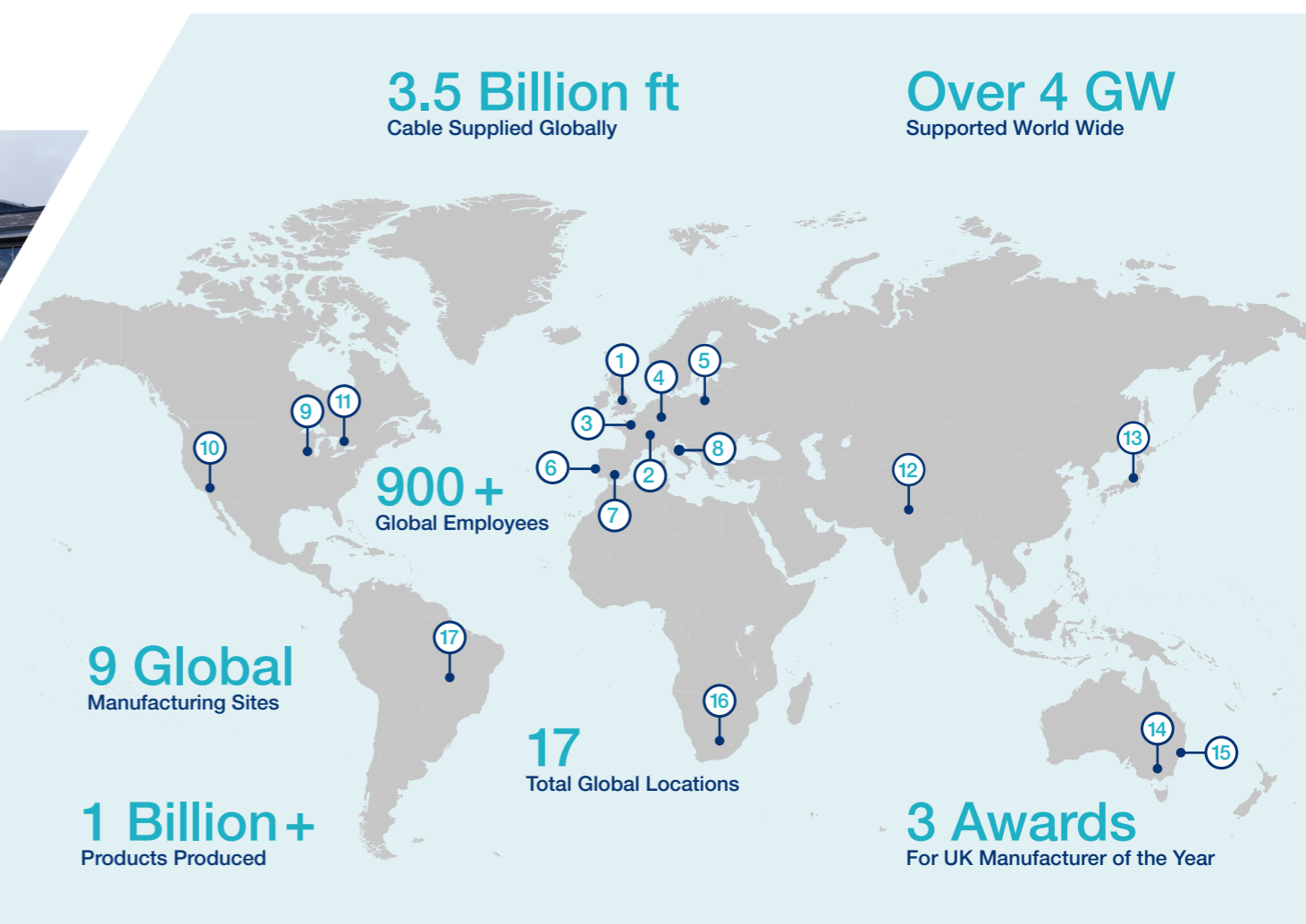

Vertically Integrated Manufacturing

An award-winning manufacturer, we create finished Gripple solutions from components we also produce in-house. Our vertically integrated operations produce our own die castings, injection moulded components, steel pressings and wire accessories. We even design and build our own automated manufacturing machinery!

Through ways of working including lean manufacturing and just-in-time inventory management we ensure streamlined processes and maximum value delivery. Our employee-owners are empowered to identify opportunities for continuous improvement, which result in greater efficiencies, better quality and improved customer satisfaction.

Continual investment in our manufacturing and supply chain means we're a trusted partner for our customers, able to consistently deliver quality, reliability, and value.

Changing the Game in 85 Countries Worldwide

Our global manufacturing and distribution footprint has been designed to deliver our innovative Gripple solutions, on-time, to over **8,000 customers**, at more than **16,000 drop points** in **85 countries** worldwide. Over **900 employee-owners** around the globe, in every one of our sites is united by this commitment to our customers. Some of our original customers have become partners in Europe, Asia, and Oceania, to strengthen our global supply chain and deliver value for our customers.

Gripple United Kingdom

1 Global Head Office – Sheffield, UK

Gripple Europe:

2 Gripple Europe Head Office – Obernai, France
 3 Paris, France
 4 Aßlar, Germany
 5 Warszawa, Poland

Europe Partners:

6 Gripple, Portugal
 7 Gripple, Spain
 8 Gripple, Italia

Gripple INC:

9 Gripple INC Head Office – Aurora, Illinois
 10 Los Angeles, California

Gripple Rest of the World:

11 Toronto, Canada
 12 New Delhi, India
 13 Kobe, Japan

Rest of the World Partners:

14 Gripple Australia – Victoria
 15 Gripple Australia – Newcastle
 16 Gripple South Africa
 17 Gripple Brazil, Hartbau



Changing the Game in Solar Cable Management

Our engineers have designed a range of simple, fast and long-lasting solutions which change the game in utility scale solar cable management.

Whether you are managing feeder or string cables, on a tracker or fixed tilt project, we have a range of direct fix and messenger cable solutions, specifically engineered to offer best in class wiring reliability, install speed and project safety.



Best in Class Cable Protection



Safe On Site Working



Fast Easy Installation



Reliable Project Delivery

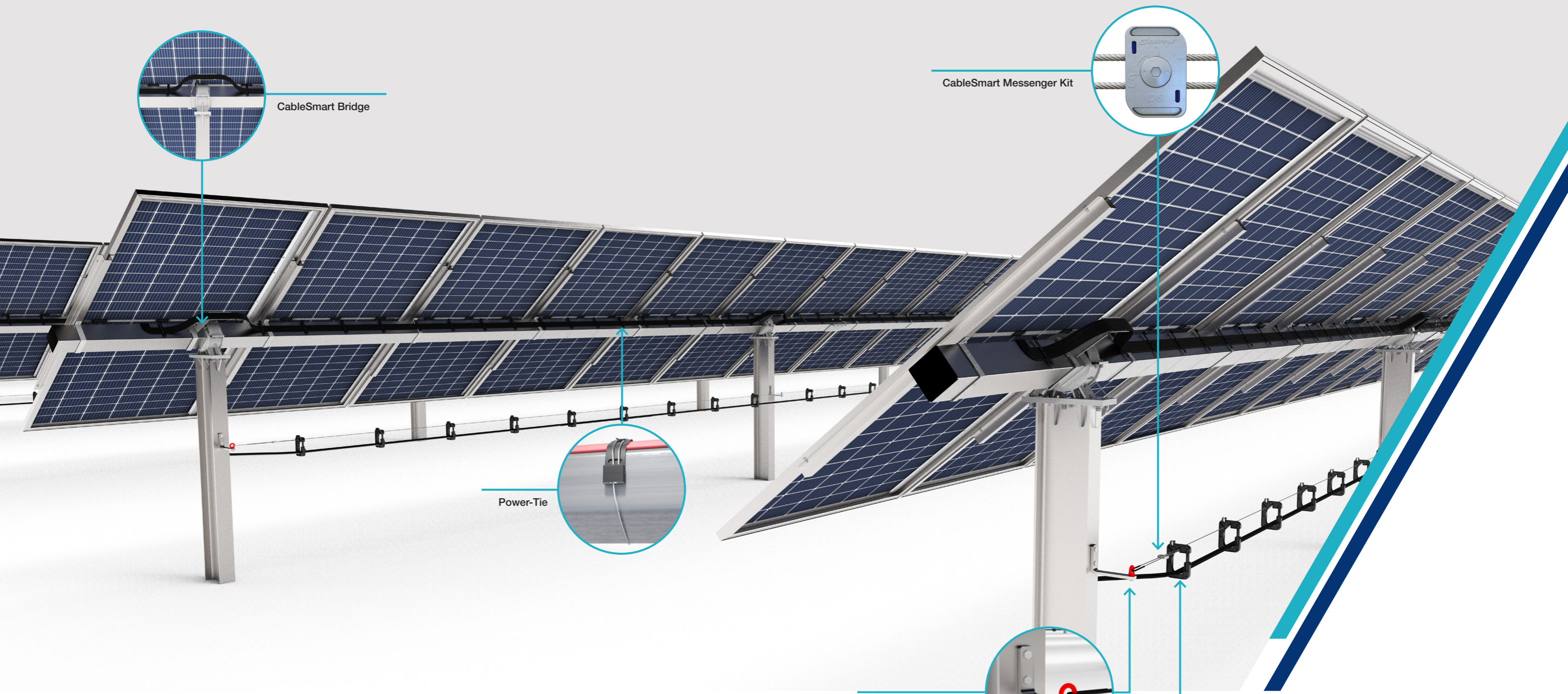

CableSmart Bridge

CableSmart Messenger Kit

Power-Tie

CableSmart Messenger Brackets

CableSmart Mini Hanger

Our String Cable Management Solutions

Whether you are managing cables directly fixed to your PV structure or using a separate messenger system, our engineered solutions offer maximum cable protection, longevity and install simplicity.

Use our CableSmart string system for maximum cable protection away from your frame structure. Or choose our Power-Tie solution to manage cables directly on your PV racking, with the durability of steel banding and the ease of install and versatility of cable ties.

Engineered by Gripple for simple, fast and long-lasting installations our string cable management solutions put the power back in your hands.

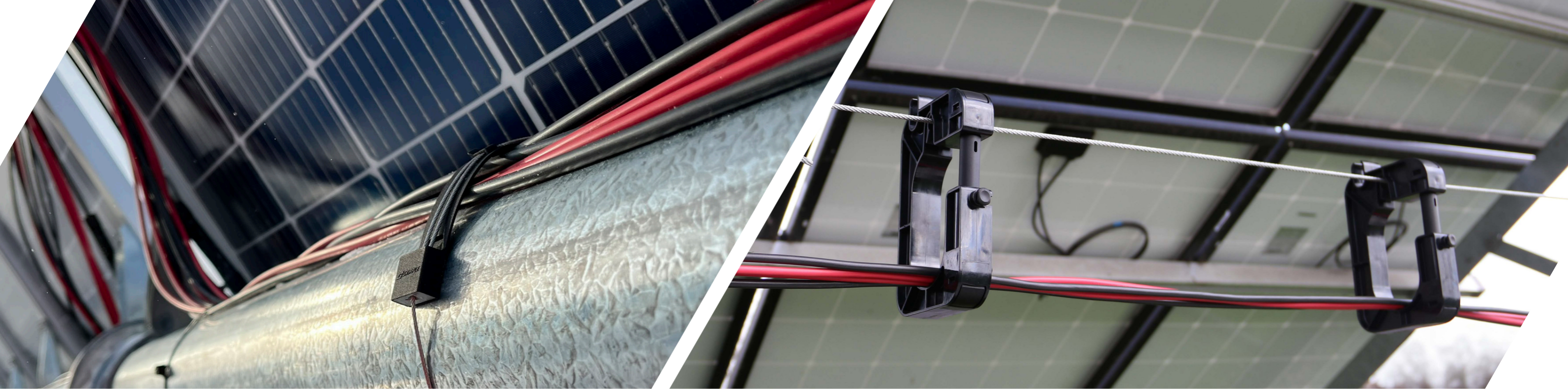

String Cable Management

Direct Fix Solution

Power-Tie

Engineered for lasting performance, Power-Tie combines the robust strength and endurance of steel banding with the ease of install and versatility of cable ties.

- + Simple Install – As easy and fast as a traditional zip tie
- + Reduced Replacement Costs – Designed to last 20+ years
- + Use Anywhere – With 3 size options you can use on any type of structure
- + High Strength – Comparable with steel banding and ties giving you confidence to use anywhere
- + No Waste – 3 size options with no need to cut excess wire on site
- + Safe To Install – Tool free with no RSI risks



Catenary Solution

CableSmart String System

Manage string cables away from your frame structure for maximum protection using our CableSmart string solution, including the fastest to install messenger catenary system on the market.

- + Protects Cables – Protects cables long term from abrasion and mechanical damage
- + Install at Speed – The fastest to install solar messenger system on the market
- + Designed to Last – 30+ years
- + Rapid Tension – Use the Gripple Dynamic wire tensioner and Gripple Torq Tool to tension your messenger wire in seconds
- + Developed for String Cabling – Developed with EPC's and contractors for string cabling
- + Lightweight Solution – Delivered in lightweight easy-to-handle boxes simplifying logistics on and off site

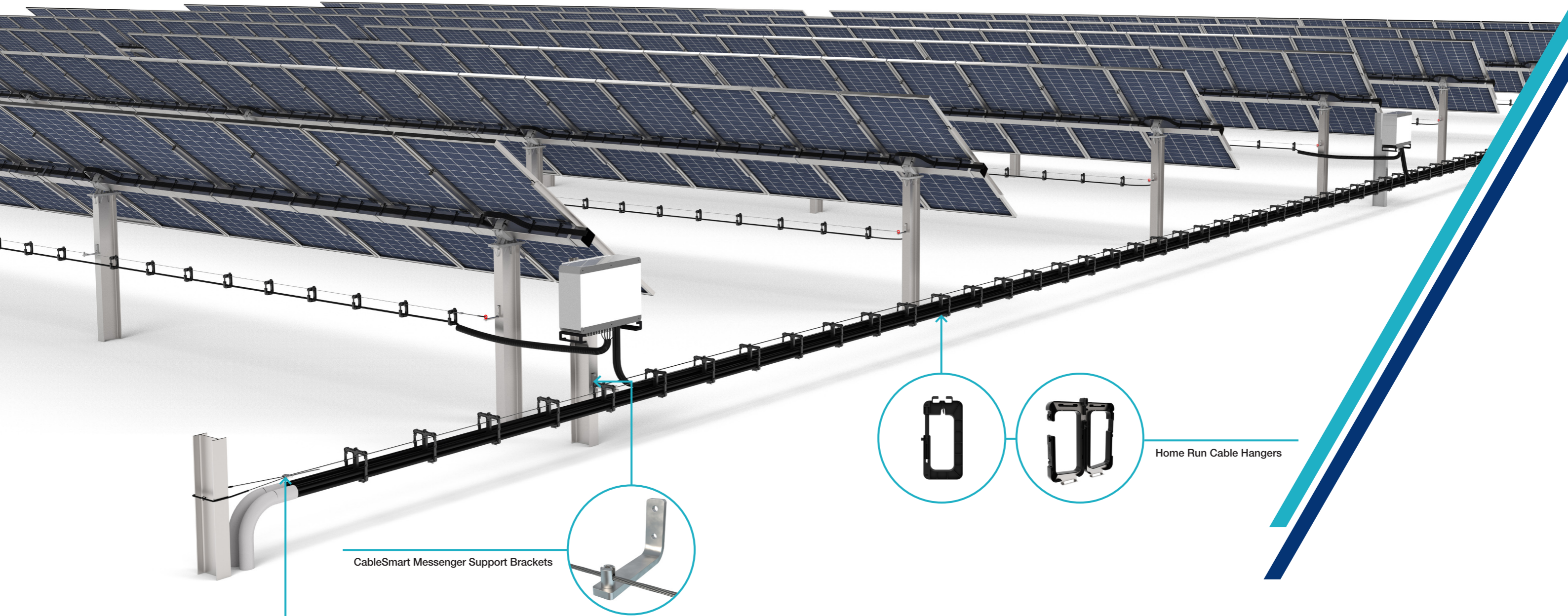

CableSmart Messenger Support Brackets

Home Run Cable Hangers

CableSmart Messenger Kit

Our Home Run Cable Management Solutions

Safely manage your home run cables above ground with our CableSmart messenger system, engineered for simple and fast installation with optimum cable protection.

We have developed CableSmart working with EPC's, contractors and developers specifically for utility scale solar applications. Whether you are managing cables above ground to mitigate site issues, or to reduce excavation costs, our CableSmart system is a simple and reliable solution. Thanks to our innovative Gripple technology, the CableSmart system is faster and easier to install than anything else on the market.

Home Run Cable Management

- + Protects Cables – Prevents long term abrasion and mechanical damage
- + Install at Speed – The fastest to install solar messenger system on the market
- + Designed to Last – 30+ years
- + Rapid Tension – Use the Gripple Dynamic wire tensioner and Gripple Torq Tool to tension your messenger wire in seconds
- + Engineered for Home Run Cables – Developed with EPC's and contractors specifically for home run feeder cables
- + Lightweight Solution – Delivered in easy-to-handle boxes simplifying logistics on and off site

Managing Cables Above Ground



Mitigate Ground Issues

From hard rocky ground to flood plains or archaeological sites, where trenching is not an option, moving cables above ground is a simple and viable solution.



Avoid Project Delays

Move your cabling above ground and avoid trenching hold ups from bad weather, saturated earth or unpredictable ground conditions.



Fast To Install

Your team can install our Gripple above ground cable management system quickly and easily using just hand tools.



No Heavy Equipment Needed

With no need for trenching, you can forget about the extra cost or logistical issues of getting heavy plant machinery to site.



Install On Landfill Or Brownfield Site

Open up unusable land for solar power generation by moving cables above ground, avoiding protective membranes or caps.



Easy O&M

Inspecting and maintaining your cable system is easier and more cost effective when they are accessible above ground.



Our Products Cable Smart Hangers

CableSmart Mini Hanger

Our CableSmart Mini Hanger has been specially designed for string cable management, offering maximum cable protection and easy side loading.

- + Working Load: 10 kg | 22 lbs
- + Max Cable Bundle: 33 cm² | 5 in²
- + Max Cable Diameter: 32 mm | 1.25 in
- + Working Temperature: -40 to +90°C | -40 to +194°F

Approvals:
 + UL2239
 + CSA 22.2

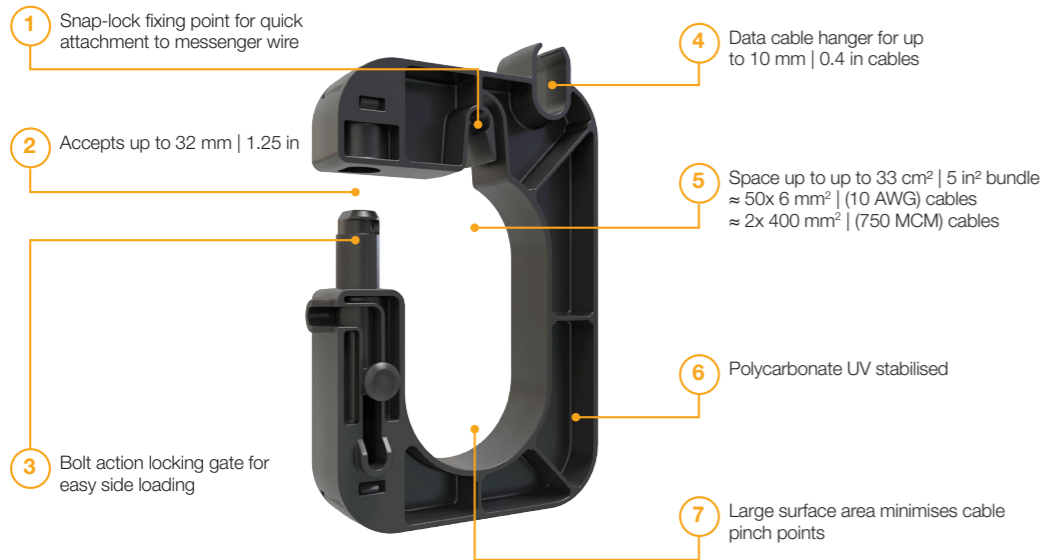

CableSmart Single Hanger

Engineered for easy installation and optimum cable protection in home run cable management.

- + Working Load: 30 kg | 66 lbs
- + Max Cable Bundle: up to 115 cm² | 17 in²
- + Max Cable Diameter: 60 mm | 2.36 in
- + Working Temperature: -40 to +90°C | -40 to +194°F

Approvals:
 + UL2239
 + CSA 22.2



Cable Smart Hangers

CableSmart Double Hanger

Safely manage up to thirty 750 kcmil home run cables above ground with our high capacity CableSmart Double Hanger.

- + Working Load: 30 kg | 66 lbs
- + Max Cable Bundle: up to two x 120 cm² | 18 in²
- + Max Cable Diameter: 34 mm | 1.34 in
- + Working Temperature: -40 to +90°C | -40 to +194°F

Approvals:
 + UL2239
 + CSA 22.2



+ Double stack for high capacity up to 30x 750 kcmil cables

CableSmart Hanger Spacer

Easy to install drop in spacing accessory for temperature adjusted separation of cables in the CableSmart Double Hanger.

- + 6 mm | ¼ in separation
- + Stackable design to allow for various spacing requirements
- + UV stabilised polycarbonate

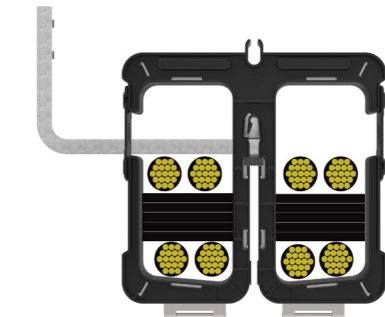

Our Products CableSmart Messenger System

CableSmart Messenger Kit

Using our Gripple Dynamic tensioner our CableSmart Messenger Kit is the fastest to install solar cable catenary system on the market.

- + Max working load: 1750 kg | 3860 lbs
- + Kit Variants: 3 mm or 6 mm | 1/8 in or 1/4 in
- + Design Life: 30 Years +
- + Working Temperature: -20 °C to +70 °C | -4 °F to +158 °F

- Approvals:**
- + UL2239
 - + CSA 22.2

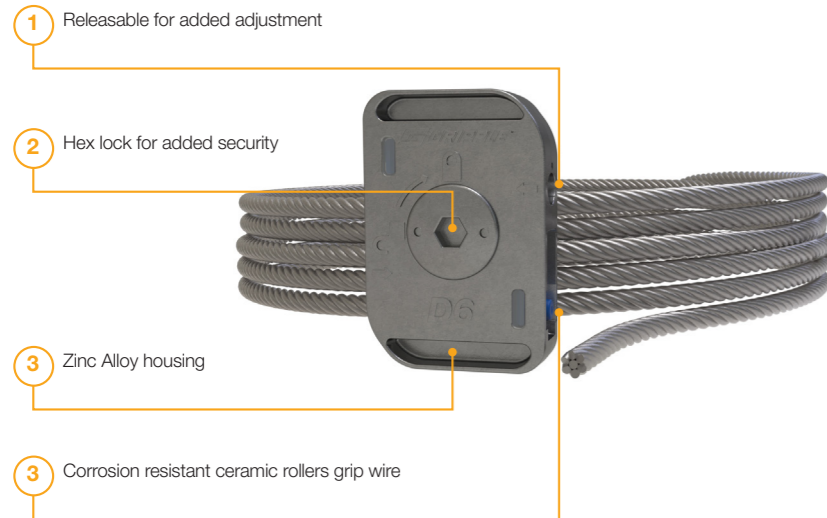

Accessories:

- + Gripple Tensioning Tool - Tension your messenger kit in seconds with the Gripple tensioning tool.

CableSmart Messenger Support Brackets

Our CableSmart Messenger Support Brackets support the Messenger Kit at intervals and hold tension allowing for longer catenary spans.

- + Variants: 155 mm or 250 mm | 6.10 in or 9.98 in
- + Working load: 200 kg | 440 lbs
- + Design Life: 30 Years +
- + Working Temperature: -40 to +200°C | -40 to +390°F

- Approvals:**
- + UL2239
 - + CSA 22.2

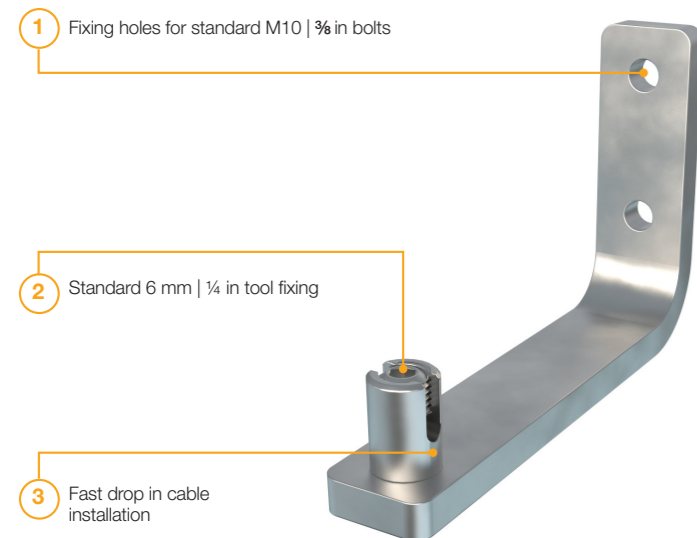

Fixing Variants:

+ Drop In Fixing – Ideal for securing messenger wire at intervals to hold tension.

+ Eyenut – Can be used for messenger wire start and end points where high loads are not required.

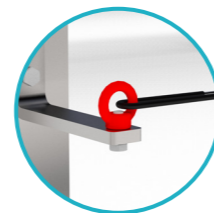
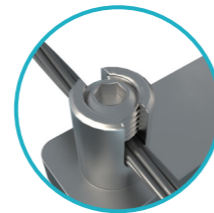

Direct Fix Solutions

Power-Tie

Engineered for fool proof installation and designed to last for 20+ years, even in harsh conditions. Power-Tie gives you the confidence you have installed right first time, every time.

- + Working Load: 120 kg | 260 lbs
- + Standard Length Options: 350 mm | 14 in, 550 mm | 22 in & 750 mm | 30 in
- + Design Life: 20 Years +
- + Working Temperature: -40 to +90°C | -40 to +194°F

- Approvals:**
- + UL/CSA/IEC 62275
 - + UL94 V-2

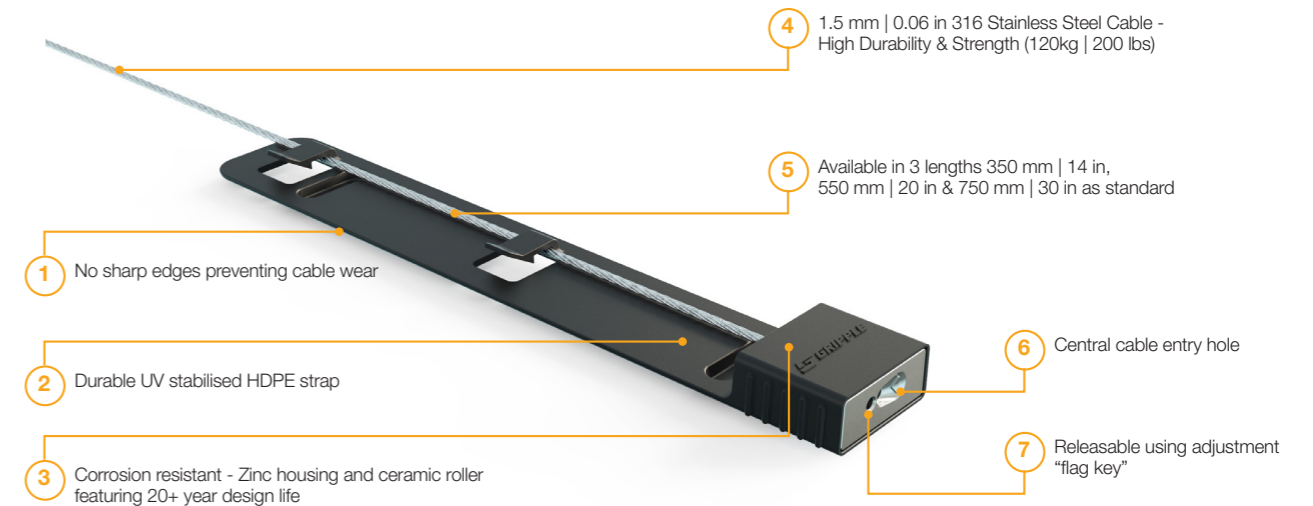

CableSmart Bridge

Safely and securely manage string cables over tracker bearings using our easy to install solar cable management bridge.

- + Working Load: 2 kg | 4.4 lbs*
- + Working Temperature: -40 to +200°C | -40 to +390°F
- + Design Life: 30 Years +
- + Compatibility: Array Technologies (ATI) Torque Tubes



*Before deflection occurs. For deflection data or additional load information contact Technical Services.



Technical Support

Project Installation & Design Support

Here at Gripple, we pride ourselves on more than just game changing products; our dedicated team of solar experts are on hand to deliver highly customised technical support from initial concept to final delivery.

We can provide comprehensive services including project design drawings, engineering calculations, and product modeling to help you achieve optimal results.

To maximise project efficiencies, involve our team as early as possible. During the proposal phase, we can provide multiple options for consideration, enabling you to maximize savings on both labour and materials by selecting the most efficient solution.

Engineering Calculations

Comprehensive structural and capacity calculations to support project requirements and product integration, including, catenary design load and sag analysis, foundation calculations, structural modeling analysis and geomembrane securement analysis.

Design Drawings

Developing detailed structural and site design drawings to support your specific project requirements, ensuring procurement efficiencies, best practice design layout and installation arrangements.

3D Library

We can provide a comprehensive library of 2D and 3D product CAD resources.

1-1 Project Engineering Support

Our Gripple technical team will be on hand at every stage of your project to provide one on one engineering support and advice.

On-Site Support

Our dedicated solar technical team are on hand to provide personalised on-site support from inception to completion of your project.

We can provide a range of on-site support services including installation training, product performance tests, and thorough site condition inspections, ensuring optimal performance and efficiency for your solar projects.

Site Product Tests

Where our product performance can differ based on the soil properties of your site, our engineering team are available to provide on-site real-world testing to validate performance for your specific project.

Installation Training & Support

Are you or your team new to our systems? The good news is they are designed for safe, simple and easy installation. However, if you still need support our dedicated solar technical team are available to provide on-site training and best practice guidance as and when needed.

Site Inspection and Planning

There is sometimes no alternative to actually being on site. Our solar technical team are available to attend site at every stage of your project if needed helping to aid product selection and provide best practice guidance and support.



The *fastest* & *easiest* way to **join&tension** wire since 1989

Our wire tensioning innovations have changed the game in applications from electrical suspension to vineyard trellising.

GRIPPLE TECHNOLOGY



Corrosion resistant ceramics ensure performance year after year

Roller or wedge technology can handle loads up to 2,800 kg / 6,170 lbs

One directional wire channel allows for easy joining and tensioning

Twin channels allow you to create loop fixings in seconds



Grippple Ltd (Headquarters)

The Old West Gun Works
Saville Street East
Sheffield S4 7UQ
UK

T +44 (0) 800 018 4265
E info@grippple.com

Grippple Europe SARL

1 Rue de Commerce
BP 37
67211 Obernai Cedex
France

T +33 (0)3 88 95 44 95
E frinfo@grippple.com

Grippple Inc

1611 Emily Lane
Aurora
IL 60502
USA

T +1 866 474 7753
E usinfo@grippple.com

Grippple India

C-115 Industrial Area
Phase 1, Naraina
New Delhi - 110028
India

T +91 11-40582703
E ininfo@grippple.com

Grippple Canada Inc

6665 Tomken Road
Units 9 -10
Mississauga
ON L5T 2C4

T +1 905 458 8700
E cainfo@grippple.com

Grippple Japan K.K

2-57 Tsukizi-cho
Hyogo-ku, Kobe-shi
Hyogo, 652-0845
Japan

T +44 (0) 800 018 4265
E info@grippple.com

grippple.com

