

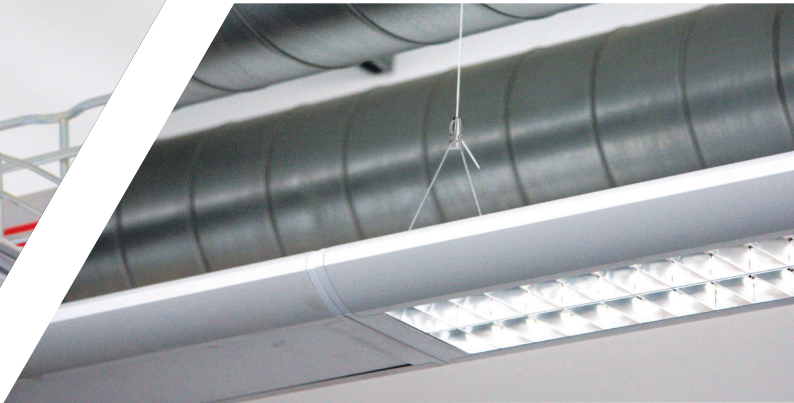

Hanger Systems

For suspending M&E services, HVAC and signage



Introduction

What is a Gripple® hanger?

The Gripple hanger is supplied as part of a complete suspension kit, comprising the hanger and a high-tensile wire rope with a choice of fixing attached to it. The Gripple hanger incorporates a patented self-locking fastener mechanism that not only secures the wire rope, but also allows adjustment of the installation height.

The Gripple hanger is specifically designed to enable quick and easy installation of a variety of MEP (mechanical, electrical and plumbing) services and is a proven replacement to traditional threaded rod and chain solutions.

Gripple hangers are manufactured in a range of five standard sizes, all with an individual safe working load (from 10 kg up to 325 kg) and a safety factor of 5:1.

How does it work?

When the wire rope is inserted into the Gripple hanger channel and pulled through the other side, it's held in place by a spring-loaded high precision serrated wedge, allowing the wire to go one way, but not the other. The wire rope is then looped through the identical channel on the opposite side, providing a means of suspension. The Gripple hanger allows full adjustment to position the object being suspended.

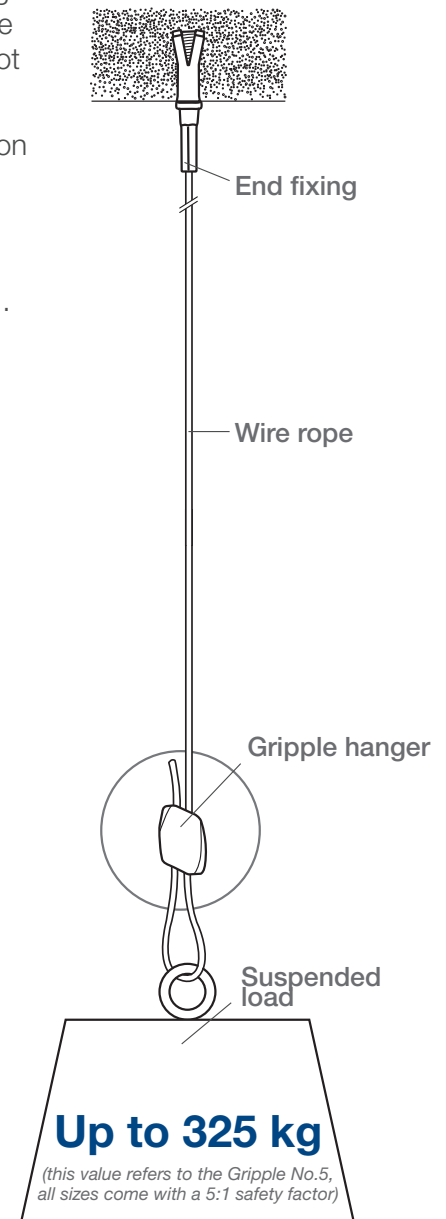
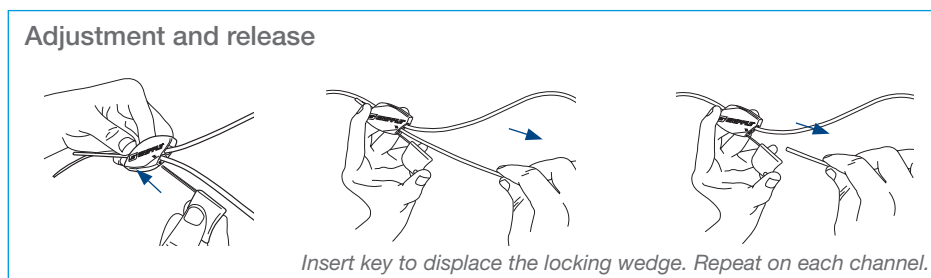
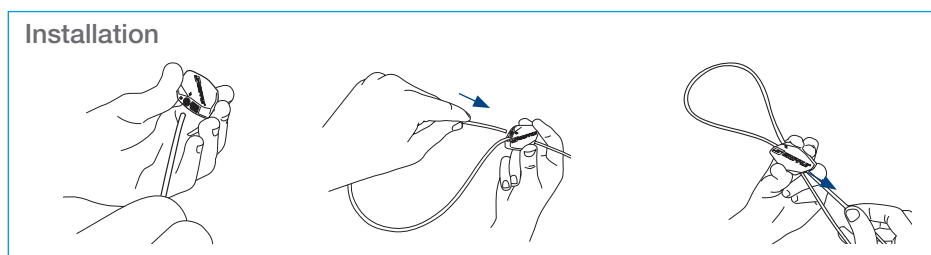

What are the benefits of using Gripple hangers?

- Saves time and money - Up to six times faster to install than traditional threaded rod.
- Lightweight and aesthetically pleasing - Discreet and lightweight, the Gripple hanger delivers a solution which is aesthetically pleasing and is also easier to handle, improving site safety.
- Strong and versatile - Gripple hangers are available in 5 load rated sizes (see Table 1 on Page 3), each designed to carry a specific weight range and designated safe working load (SWL). Gripple hangers can be installed vertically or at an angle to the suspended object (see Table 2 on Page 3).
- Environmentally friendly - By replacing a typical threaded rod installation with the Gripple hanger system, steel consumption is reduced by up to 95%, and vehicle movements are also reduced, lowering carbon emissions.
- Supplied in ready-to-use kits - The Gripple hanger is supplied as part of a complete suspension kit, comprising the hanger and a high-tensile wire rope with a choice of fixing attached to it. A setting key is also provided for unlocking and adjusting the Gripple hanger.

Technical information

Load ratings

Gripple hangers are available in 5 load rated sizes. Each size is designed to carry a specific weight range and has a designated safe working load (SWL). The SWL gives a minimum 5:1 safety factor in a vertical plane and applies to all lengths and end fixings, unless stated otherwise.

Table 1

Wire rope size	Weight Range	Safe Working Load
No.1	0 - 10 kg	10 kg
No.2	11 - 45 kg	45 kg
No.3	46 - 90 kg	90 kg
No.4	91 - 225 kg	225 kg
No.5	226 - 325 kg	325 kg

Hanging at angles

The load rating for a Gripple hanger is based on the suspension being hung vertically. If the wire rope is suspended at an angle, an additional sideways load is applied which reduces the load capacity of the overall suspension. The net effect is shown in the table below.

Table 2

Hanger size	Maximum load (kg) at an angle from vertical				
	0°	15°	30°	45°	60°
No.1	10	9.6	8.6	7	5
No.2	45	43	39	32	22
No.3	90	87	78	64	45
No.4	225	217	195	159	113
No.5	325	314	281	230	163
Load %	100	96	86	70	50

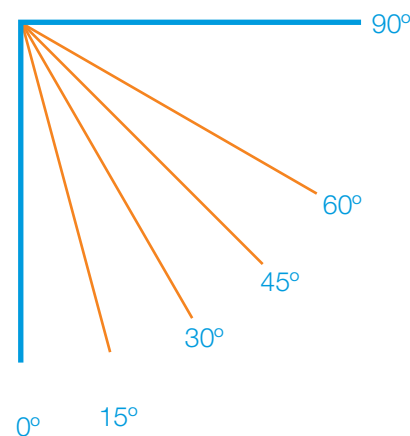

No Gripple hanger should be hung at an angle in excess of 60° from vertical

Quality and approvals

Quality is everything to Gripple; not just in the products we make and the manufacturing process we employ, but the way we do business. Our compliance to BS EN ISO9001 at our Sheffield manufacturing plant is the backbone of our own quality management system achieved under the auspices of the reputable LRQA.



Gripple's policy is one of continuous development and innovation. We therefore reserve the right to alter specifications, etc. without notice.

Applications- HVAC: Ventilation

Rectangular ducting, spiral ducting, oval ducting and PI foam ducting



Spiral ducting

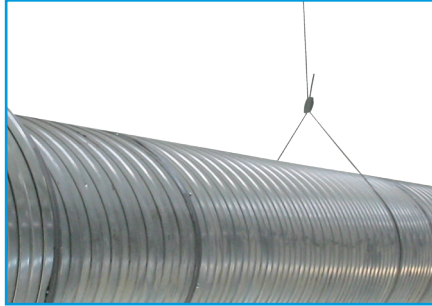

Spiral ducting



Oval ducting

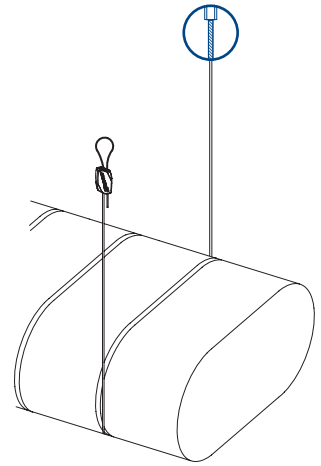
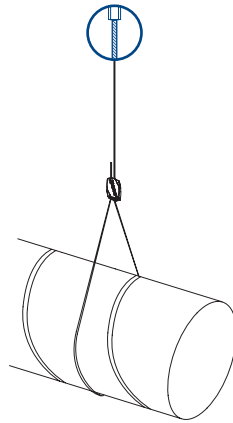
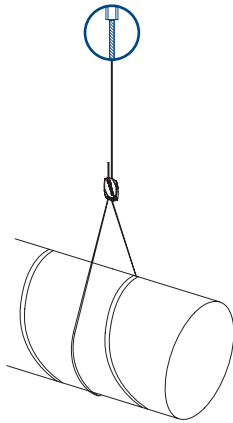

Rectangular ducting



Rectangular ducting



PI foam ducting

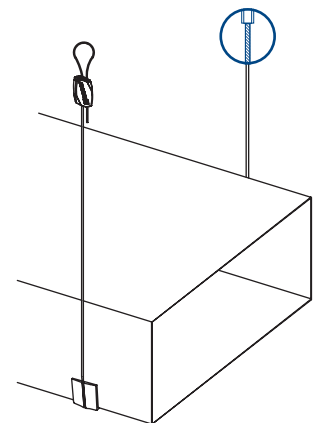
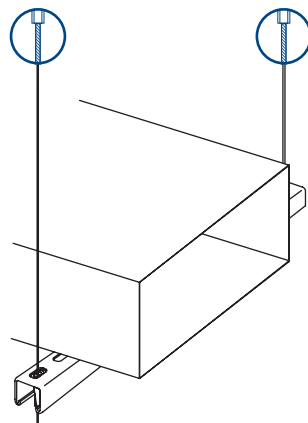
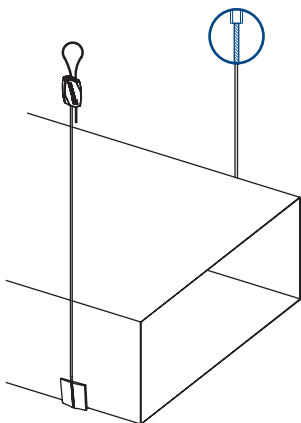

HVAC: Air Conditioning

Fabric ducting, swirl diffuser, plenum boxes, air conditioning units, refrigerant pipes and condensate pipes



Fabric ducting

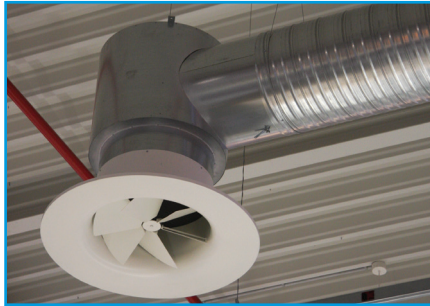

Swirl diffuser



Plenum boxes

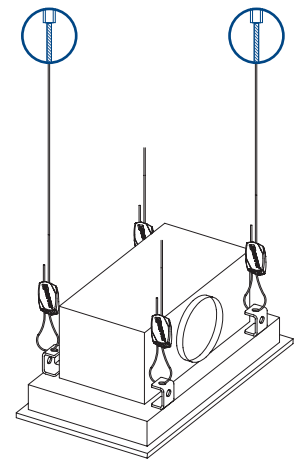
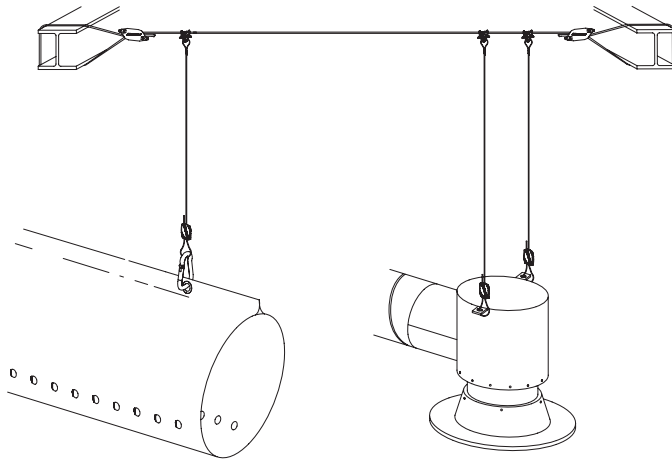

Air conditioning units



Refrigerant pipes



Condensate pipes

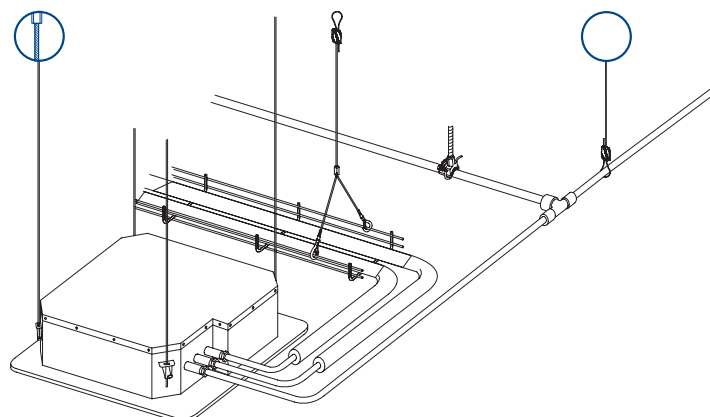

Mechanical

Copper pipes, steel pipes, intermediary supports, bracing and pipe rack



Copper pipes



Steel pipes



Plastic pipes

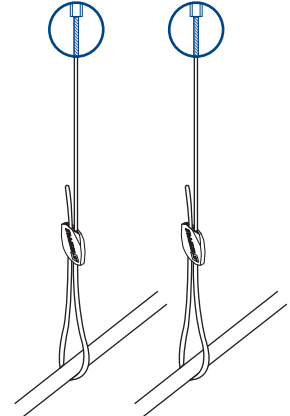
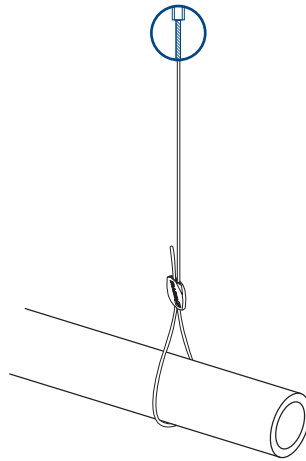
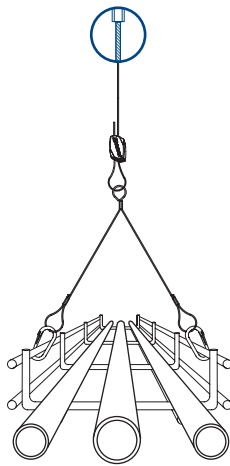

Intermediary supports for steel pipes

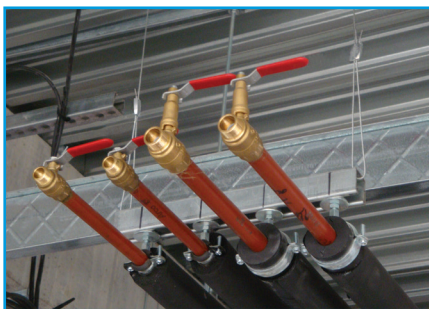

Steel pipes



Bracing for steel pipes

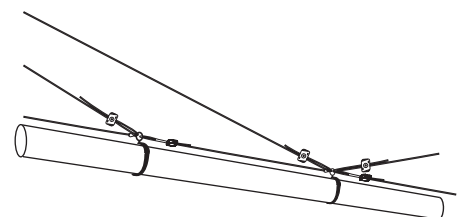
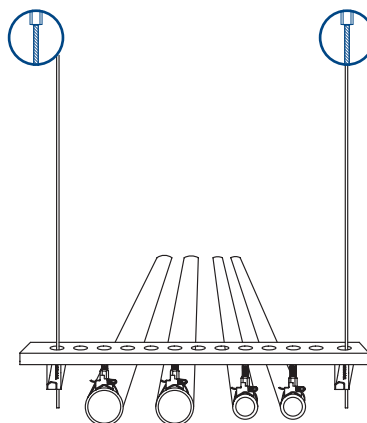
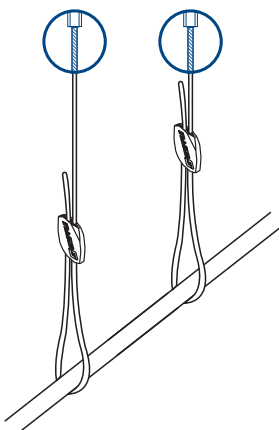

Electrical: Cable Containment

All types of cable containment on basket or tray

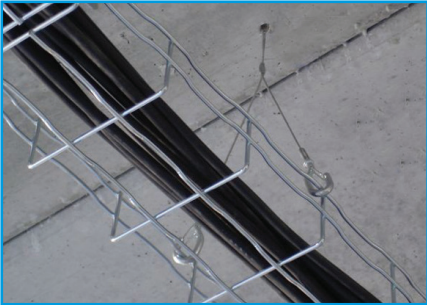

Cable basket

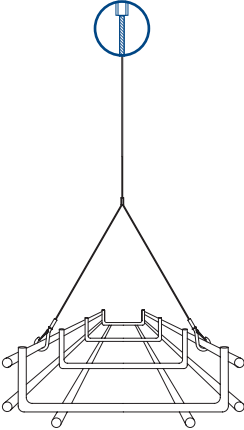

Cable basket

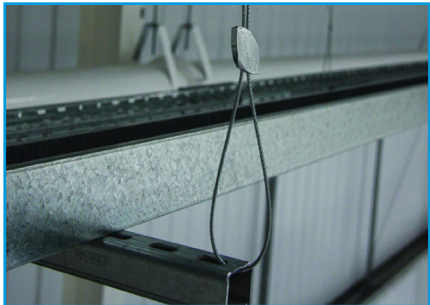
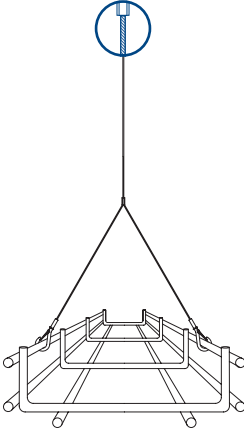

Perforated cable tray on channel

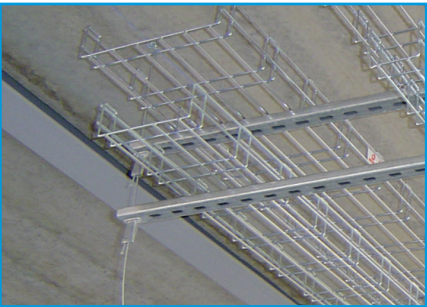
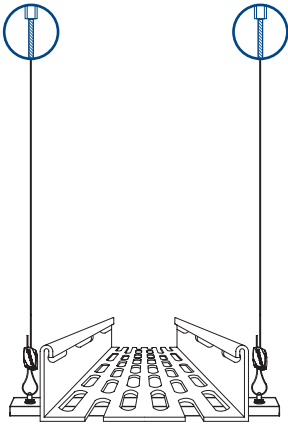

Multi-tiered cable basket on Trapeze

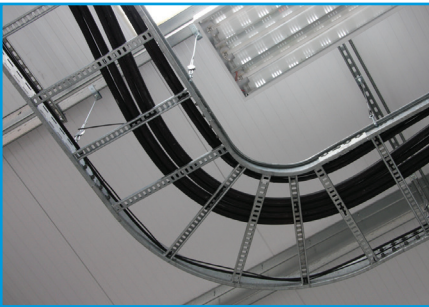
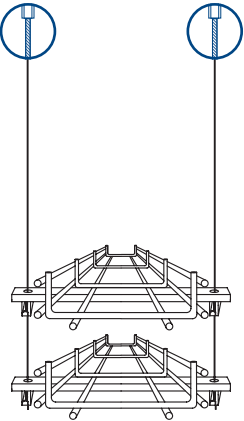

Ladder

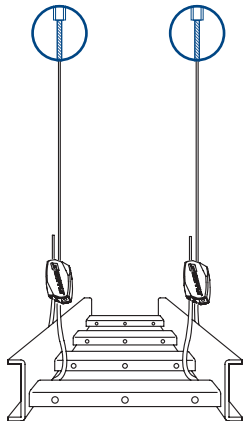

Multiple cable trays on single channel

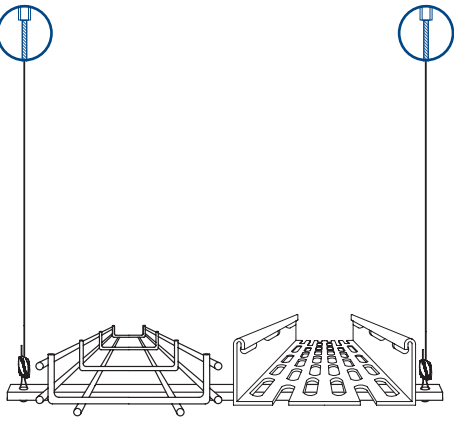

Electrical: Lighting

All types of hanging solutions for lighting



Industrial high bay



Strip lighting



Panel lighting

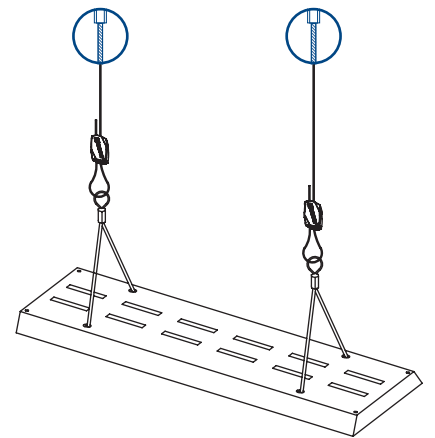
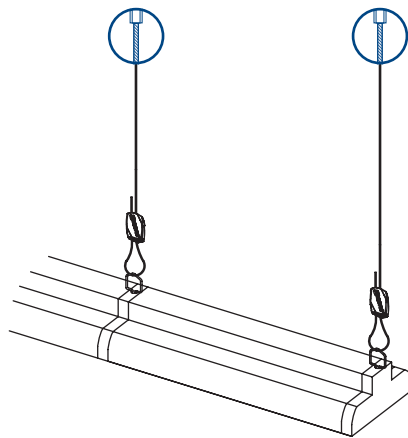
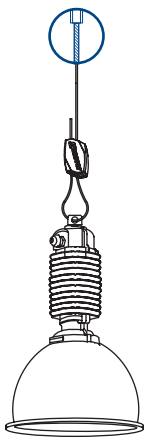

Busbar



Lighting and Camera on Catenary

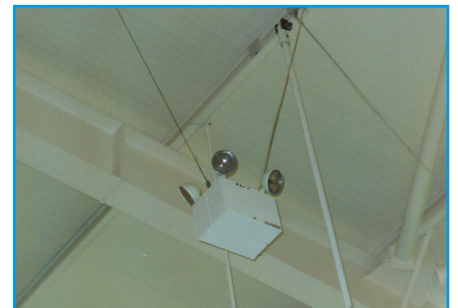

Emergency Lighting

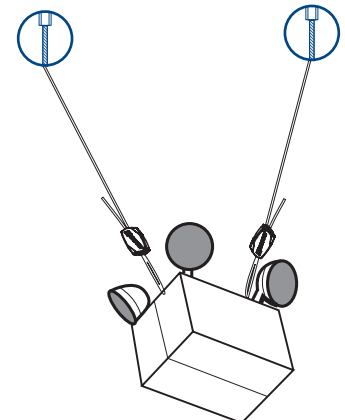
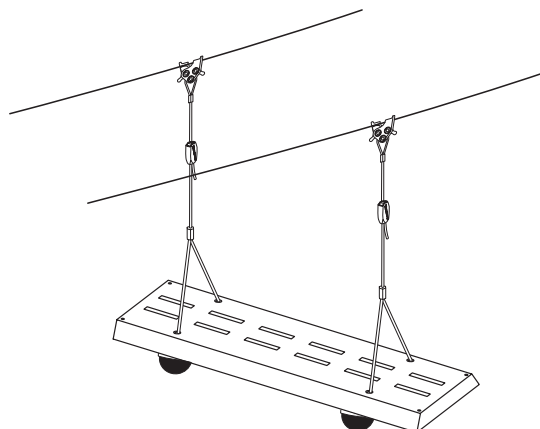
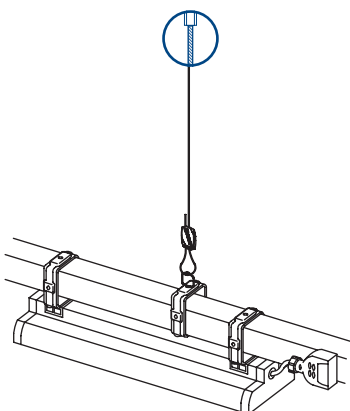

Electrical: Lighting

Architectural lighting suspensions when aesthetics are important



Angel

A variety of feet for suspending all types of lighting, signage and acoustic panels



From left to right: Y-Fit, Integrated Side Hook, Side Exit - Female, Side Exit - Male, Central Exit, Signage, Swivel, Signage Rail, Disc

Signage



In store signs

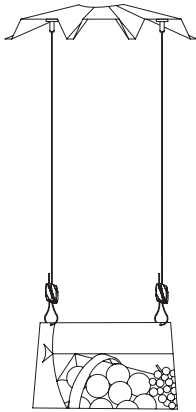

Information signs

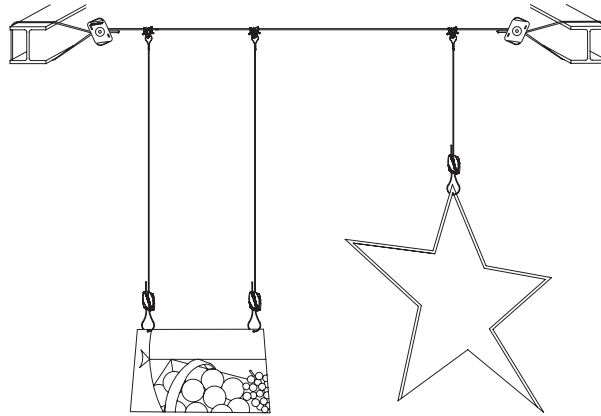

In store decorations

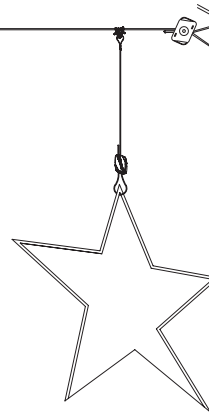

Cold Rooms

For positive and negative temperatures



Sandwich panel



Under panel lighting



Under panel evaporator

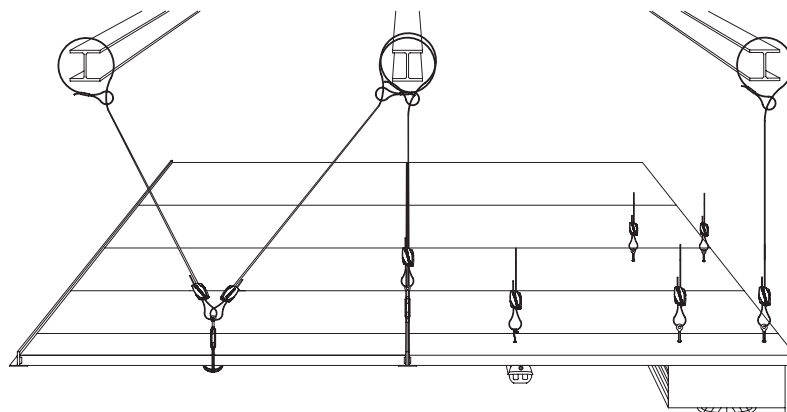

Suspended Ceilings

Suspended ceilings, acoustic baffles and decorative panels



Acoustic baffles



Suspended raft ceilings



Contoured raft ceilings

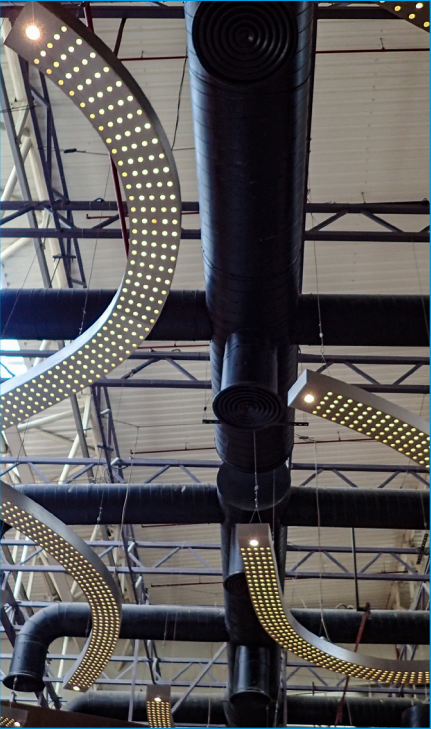

Decorative ceiling panels

Catenaries

Horizontal wire rope solution



Busbar and Lighting



Spiral ducting



Cable tray

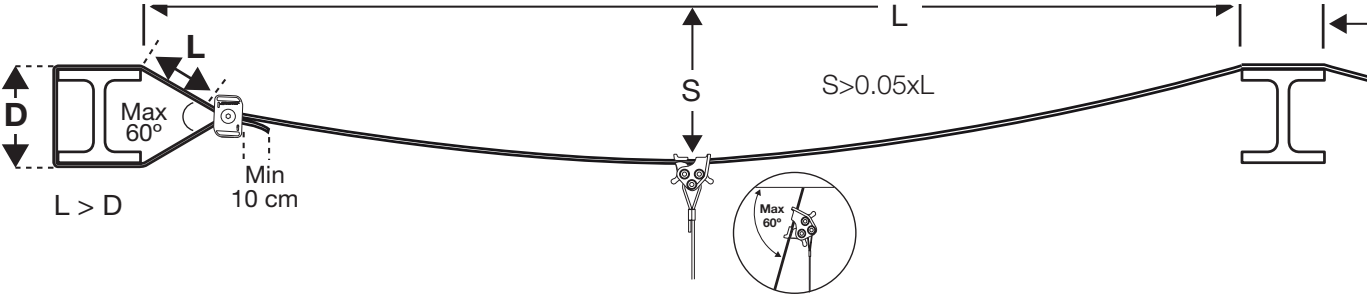
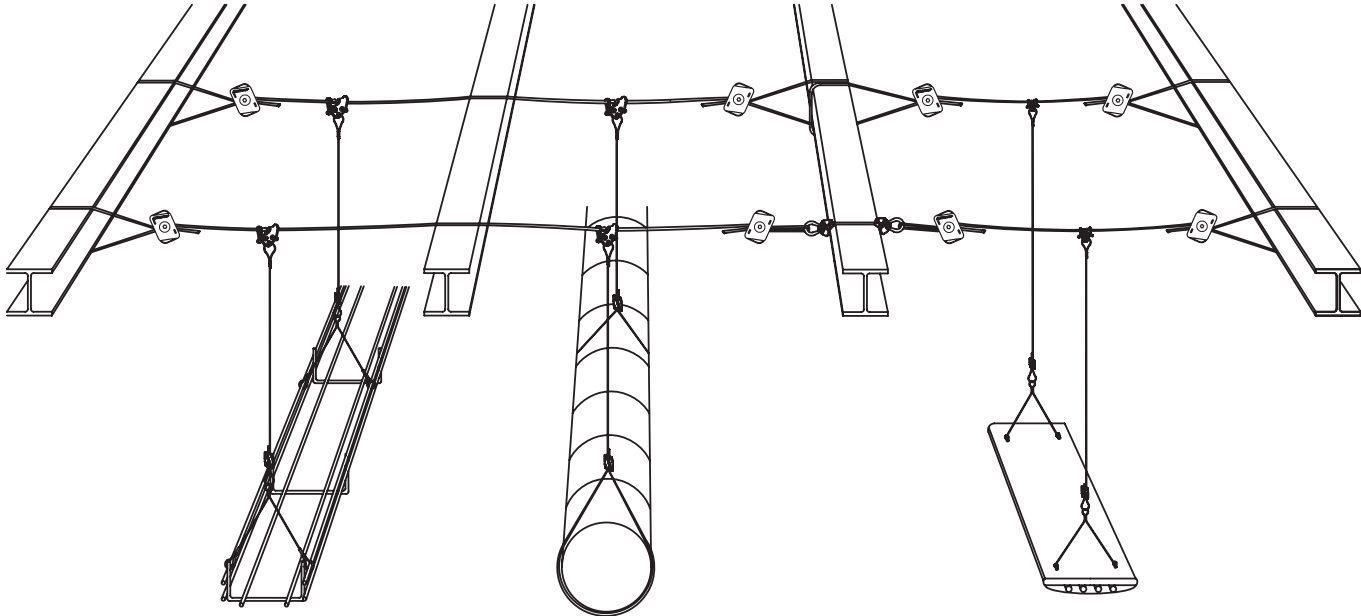

Other Applications

Fan coil units, chilled beams, decorations, loud speakers, diffuser kit & radiant panels



Decorations

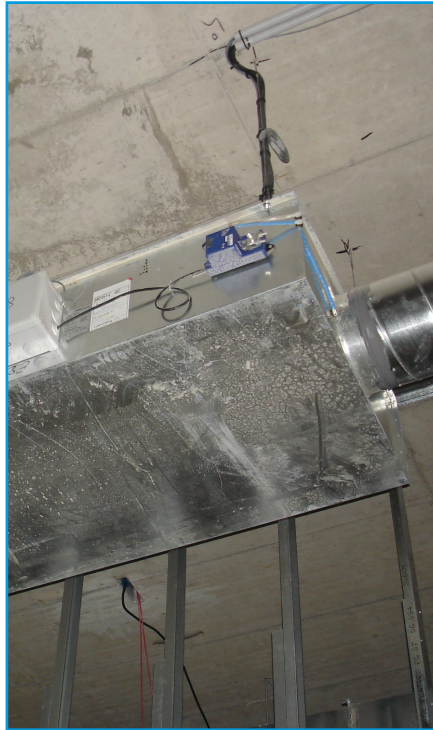

Fan coil units



Chilled beams



Loudspeakers

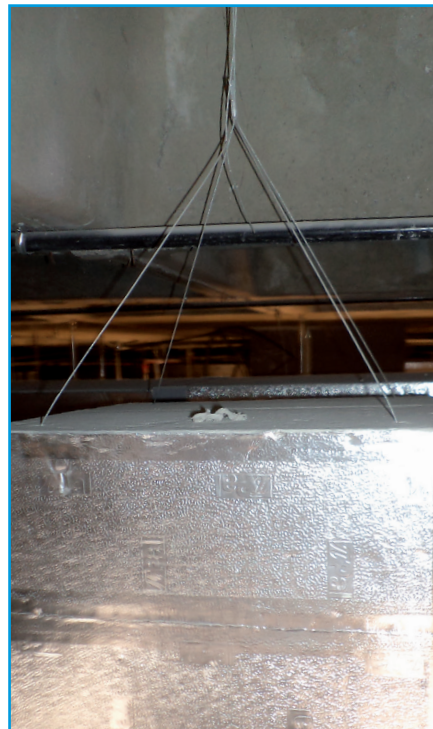

Diffuser kit



Radiant panels

Seismic Bracing Solutions

A complete kit offering secure bracing in active seismic locations

Gripple Ltd. is a leading provider of seismic bracing and blast protection systems.

In contrast to standard wire bracing, Gripple's seismic system is fully tested and approved to UL NEBS GR 63 Core Certification and has SMACNA verification, recognised as the most demanding requirement in the world.



Gripple Seismic Wire Bracing Systems

Gripple® Seismic Wire Bracing Solutions are pre-engineered systems that are up to 10 times faster to install, and can be used to brace new or retrofit nonstructural equipment or components. They require no tools to install, and no field swaging of wires. There are four wire bracing kit sizes, each with its own selection of wire lengths, end fittings, and brackets:

- GS10 Seismic Bracing Kit - Design Strength (LRFD*): 181 kg
- GS12 Seismic Bracing Kit - Design Strength (LRFD*): 429 kg
- GS19 Seismic Bracing Kit - Design Strength (LRFD*): 1027 kg
- GS25 Seismic Bracing Kit - Design Strength (LRFD*): 1619 kg

* Load Resistance Factor Design

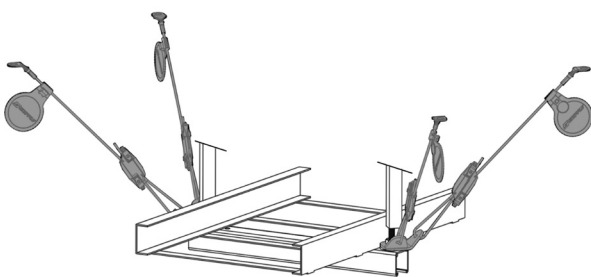

'4 Way' Bracing

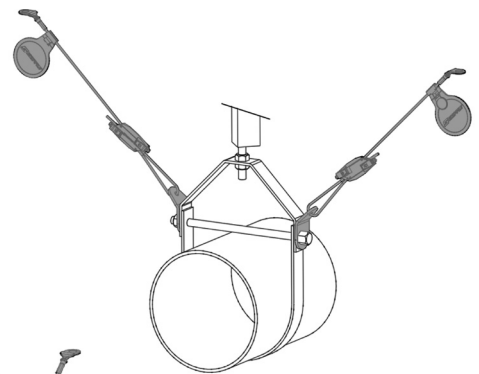

Transverse Bracing

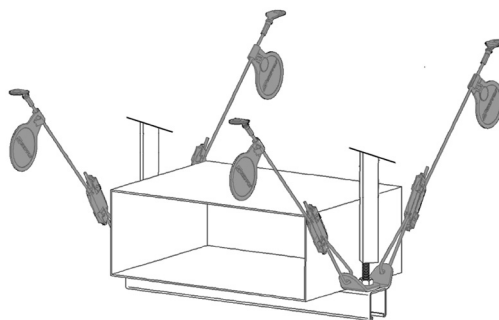

Longitudinal Bracing

Engineering Services

The complex and technical nature of seismic bracing requirements, industry regulations, and life-safety issues necessitates a partner like Gripple who can offer you complete beginning-to-end engineering services, such as:

- PE Stamped Drawings
 - Engineered seismic bracing calculations based on design category, occupancy, importance and relevant site specific seismic specifications.
 - Detailed engineer's sealed drawings (electronic format) prepared in AutoCAD or .pdf files (submitted by the consultant/contractor) indicating the location of seismic bracing points and bracket type.
- Coordination and Site Reviews - with Structural Engineer and Gripple to ensure proper installation of products.
- Gripple on-site training on seismic product installation.
- Budget Estimating - Our project quote for engineering services and products is all-inclusive and will not increase after signed off on. We do not add additional charges or fees once the project quote has been agreed upon.
- Products - And finally, we'll provide you with the appropriate quantity of complete Gripple Seismic Wire Brace Assembly Kits and/ or vibration isolation products per Engineer's calculations for the required services.

Gripple has a wealth of experience, talents, and resources with which to provide you a complete Seismic Solution. Contact your local Gripple Territory Manager for assistance or information regarding any of the Engineering services we provide, and to ensure that your seismic bracing job is up to spec.

Approvals and Certificates

SMACNA Verification

The Sheet Metal and Air Conditioning Contractors National Association (SMACNA) has deemed Gripple® Seismic an acceptable alternative for seismic hanger bracing in strict accordance with the ANSI / SMACNA Seismic Restraint Manual – Guidelines for Mechanical Systems.

UL NEBS GR 63 Core Certification

UL has awarded Gripple® Seismic the UL NEBS GR 63 Core Certification based on surpassing extensive shaker table testing requirements. Gripple® Seismic is the only seismic bracing company to hold this certification.

Additional Approvals

In addition, Gripple® Seismic has undergone all of the proper qualifications and extensive strength testing to meet any seismic design code requirements including: International Building Code, California State Building Code, National Fire Protection Association, and American Society of Civil Engineers.



'4 Way' Bracing



Longitudinal Bracing

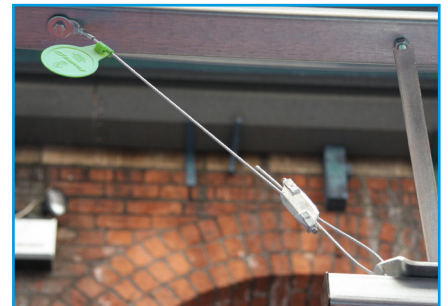

Transverse Bracing

Gripple Strut and Rigid Support System

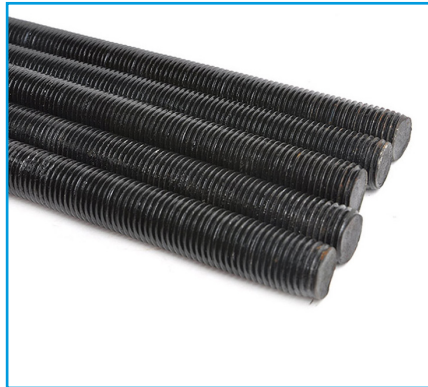
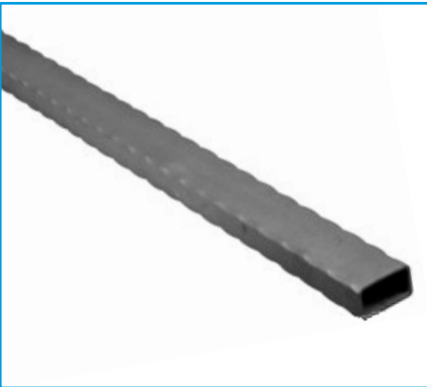
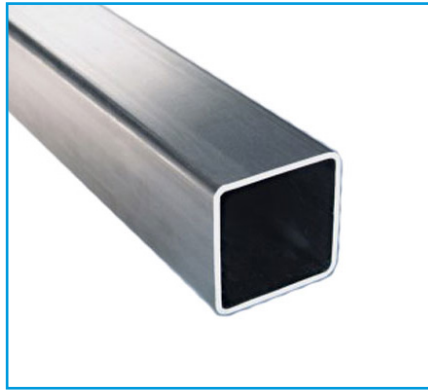

Technical Support

In situations where heavy loads need to be suspended such as heavy piping, Gripple will include a strut and rigid support system as part of the solution design. This is fixed at incremental lengths to provide additional support to the wire hanging system.

- Stress analysis

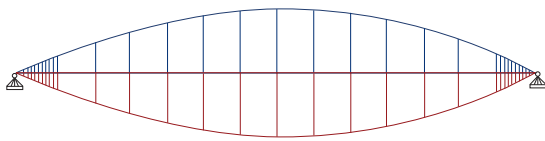

- Bespoke design as per application

- Deflection and shear analysis

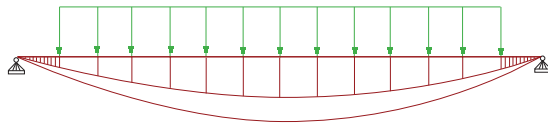

- Complete technical back-up

Strut Support System

GCS412125

FEATURES & BENEFITS

- Gripple strut support system are accurately and carefully cold formed to size from low-carbon strip steel
- Design is customised to be used with Gripple Clamping System
- Customised profiles are available, consult local Gripple Technical Representative

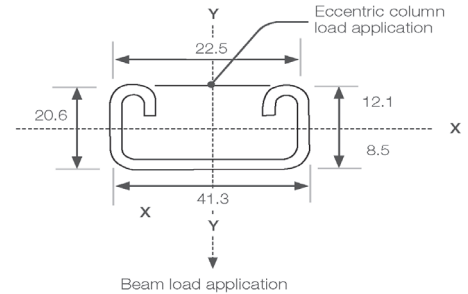

SECTION PROPERTIES

- For use with static loads only

Area	Weight	Ixx	Zxx	Zxx	rxx	Iyy	Zyy	ryy
cm ²	kg/m	cm ⁴	(top)	(bottom)	cm	cm ⁴	cm ³	cm
			cm ³	cm ³				
2.36	1.85	1.2	1	1.43	0.72	5.44	2.63	1.5

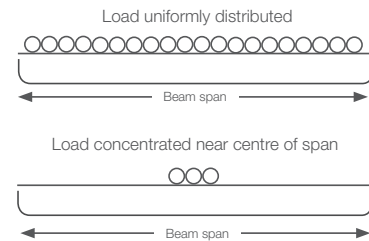

SAFE WORKING LOAD TABLE

Length (m)	Safe Working Load (kg) Uniform		Def. limit span/200 (kg)	Def. limit span/360 (kg)	Safe Working Loads (kg) concentrated		Def. limit span/200 (kg)	Def. limit span/360 (kg)	Safe column loads kg at Centre	Safe column loads kg at Face
	(kg) Load	(mm) Def.			(kg) Load	(mm) Def.				
0.6	242	2.64	242	155	123	2.11	123	98	2988	904
0.7	208	3.59	203	115	106	2.87	106	74	2481	831
0.8	182	4.68	156	89	94	3.75	94	58	2029	757
0.9	163	5.94	125	71	84	4.75	80	47	1667	687
1.0	147	7.33	102	59	76	5.86	66	39	1385	623
1.1	134	8.87	85	49	70	7.09	55	33	1166	566
1.2	123	10.55	72	42	64	8.44	47	28	994	515
1.3	114	12.38	62	37	60	9.91	41	25		
1.4	106	14.36	54	32	56	11.49	36	22		
1.5	100	16.49	48	29	52	13.18	32	20		
1.6	91	18.76	40	23	46	15.00	26	15		
1.7	86	21.18	36	21	44	16.95	23	14		
1.8	81	23.74	32	19	41	19.00	21	12		
1.9	77	26.45	29	17	39	21.16	19	11		
2.0	73	29.31	26	15	37	23.45	17	10		
2.1	70	32.31	24	14	36	25.86	16	10		
2.2	67	35.46	22	13	34	28.38	15	9		
2.3	64	38.76	20	12	33	31.01	13	8		
2.4	61	42.2	19	11	32	33.77	13	8		
2.5	59	45.8	18	11	30	36.63	12	7		
2.6	57	49.53	16	10	29	39.63	11	7		
2.7	55	53.42	15	9	28	42.74	10	7		
2.8	53	57.45	14	9	27	45.95	10	6		
2.9	51	61.62	14	8	26	49.29	9	6		
3.0	49	65.95	13	8	26	52.76	9	6		

$$\frac{\alpha L_e}{r_{xx}} > 180$$

Load uniformly distributed & Load concentrated near centre of span

Strut Support System

GCS414125

FEATURES & BENEFITS

- Gripple strut support system are accurately and carefully cold formed to size from low-carbon strip steel
- Design is customised to be used with Gripple Clamping System
- Customised profiles are available, consult local Gripple Technical Representative

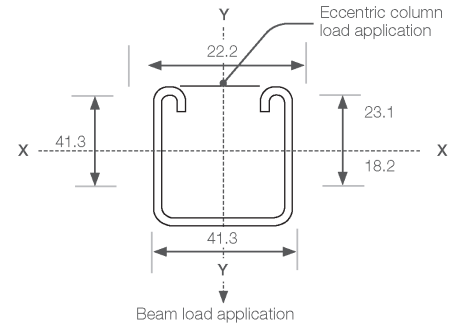

SECTION PROPERTIES

- For use with static loads only

Area	Weight	Ixx	Zxx	Zxx	rx	Iyy	Zyy	ry
cm ²	kg/m	cm ⁴	(top) cm ³	(bottom) cm ³	cm	cm ⁴	cm ³	cm
3.39	2.67	7.32	3.17	4.03	1.5	9.34	4.5	1.66

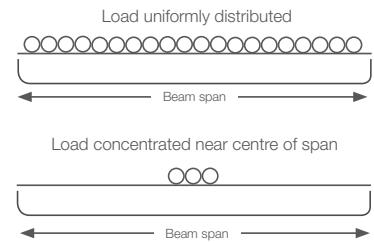

SAFE WORKING LOAD TABLE

Length (m)	Safe Working Load (kg) Uniform		Def. limit span/200 (kg)	Def. limit span/360 (kg)	Safe Working Loads (kg) concentrated		Def. limit span/200 (kg)	Def. limit span/360 (kg)	Safe column loads kg at Centre	Safe column loads kg at Face
	(kg) Load	(mm) Def.			(kg) Load	(mm) Def.				
0.6	759	1.39	759	759	382	1.11	382	382	5186	1567
0.7	651	1.88	651	651	329	1.51	329	329	4828	1506
0.8	571	2.46	571	515	288	1.98	288	288	4381	1434
0.9	508	3.11	508	408	257	2.5	257	257	3938	1361
1.0	457	3.85	457	332	231	3.08	231	209	3522	1290
1.1	416	4.66	416	275	211	3.72	211	174	3156	1221
1.2	382	5.54	382	232	194	4.43	194	147	2811	1152
1.3	353	6.51	353	198	180	5.21	180	126	2551	1094
1.4	329	7.54	305	172	167	6.04	167	109	2333	1043
1.5	3.6	8.66	266	150	156	6.92	156	96	2122	990
1.6	284	9.86	232	130	143	7.88	143	82	1971	949
1.7	269	11.12	205	115	135	8.91	129	73	1817	905
1.8	253	12.47	183	103	127	9.98	115	65	1685	865
1.9	241	13.89	165	93	122	11.11	104	59	1596	837
2.0	228	15.39	149	84	115	12.31	94	53	1496	805
2.1	217	16.97	135	76	110	13.58	85	48	1388	768
2.2	208	18.63	123	70	105	14.9	78	44	1314	741
2.3	199	20.36	133	64	101	16.28	71	41	1249	717
2.4	190	22.16	104	59	96	17.73	66	37		
2.5	183	24.06	96	54	93	19.25	61	35		
2.6	176	26.02	89	51	89	20.81	56	32		
2.7	170	28.06	83	47	86	22.45	52	30		
2.8	163	30.17	77	44	83	24.14	49	28		
2.9	158	32.37	72	41	80	25.89	46	26		
3.0	153	34.63	67	39	78	27.71	43	25		

Load uniformly distributed & Load concentrated near centre of span

Strut Support System

GOHS414125

FEATURES & BENEFITS

- Gripple strut support system are accurately and carefully cold formed to size from low-carbon strip steel
- Design is customised to be used with Gripple Clamping System
- Customised profiles are available, consult local Gripple Technical Representative

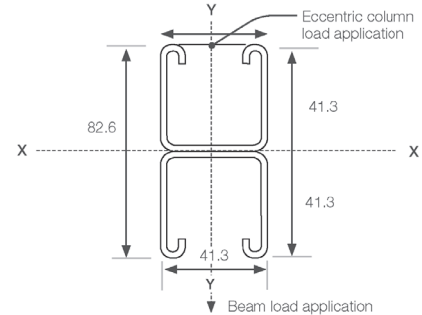

SECTION PROPERTIES

- For use with static loads only

Area	Weight	Ixx	Zxx	Zxx	rxx	Iyy	Zyy	ryy
cm ²	kg/m	cm ⁴	(top) cm ³	(bottom) cm ³	cm	cm ⁴	cm ³	cm
6.78	5.34	37.2	9.01	9.01	2.3	18.68	9.1	1.66

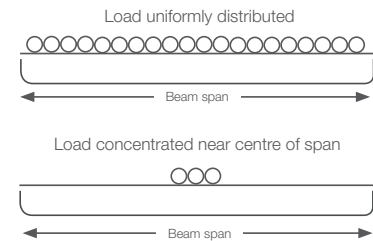

SAFE WORKING LOAD TABLE

Length (m)	Safe Working Load (kg) Uniform		Def. limit span/200 (kg)	Def. limit span/360 (kg)	Safe Working Loads (kg) concentrated		Def. limit span/200 (kg)	Def. limit span/360 (kg)	Safe column loads kg at Centre	Safe column loads kg at Face
	(kg) Load	(mm) Def.			(kg) Load	(mm) Def.				
0.6	2148	0.77	2148	2148	1077	0.61	1077	1077	11646	2896
0.7	1842	1.05	1842	1842	923	0.84	923	923	11441	2873
0.8	1612	1.38	1612	1612	809	1.1	809	809	11203	2846
0.9	1434	1.75	1434	1434	719	1.4	719	719	10922	2815
1.0	1291	2.15	1291	1291	648	1.72	648	648	10584	2779
1.1	1174	2.61	1174	1174	589	2.09	589	589	10178	2736
1.2	1077	3.1	1077	1077	541	2.48	541	541	9695	2685
1.3	994	3.64	934	986	500	2.92	500	500	9139	2626
1.4	923	4.22	923	851	464	3.38	464	464	8528	2559
1.5	862	4.85	862	742	434	3.88	434	434	7892	2486
1.6	806	5.51	806	650	404	4.4	404	404	7263	2407
1.7	758	6.23	758	576	380	4.98	380	361	6663	2326
1.8	716	6.98	716	514	359	5.58	359	322	6106	2243
1.9	679	7.77	679	461	340	6.22	340	289	5598	2161
2.0	645	8.61	645	417	323	6.89	323	261	5139	2080
2.1	614	9.5	614	378	308	7.6	308	237	4727	2001
2.2	586	10.43	586	345	284	8.35	284	216	4357	1925
2.3	561	11.39	561	316	282	9.11	282	198	4026	1850
2.4	538	12.4	520	290	270	9.92	270	182		
2.5	516	13.46	480	267	259	10.76	259	168		
2.6	497	14.56	444	247	249	11.65	249	155		
2.7	478	15.7	412	230	240	12.56	240	144		
2.8	461	16.88	383	214	232	13.5	232	134		
2.9	445	18.11	357	199	224	14.49	224	125		
3.0	431	19.38	334	186	216	15.5	209	117		

Load uniformly distributed & Load concentrated near centre of span

End Fixings

Each ready-to-use kit comes with an end fixing of your choice, ranging from the popular and versatile Loop, to more bespoke fixings designed for specific applications. We aim to provide a solution whatever the substrate as presented in our full range below, followed by detailed information on our most popular end fixings.



Loop

- Ideal for looping around purlins, beams, roof trusses and other suitable building features
- Available up to 325 kg SWL, with a 5:1 safety factor
- Comes as a ready-to-use kit with wire rope and a Gripple hanger
- Available in lengths from 1 m to 10 m
- Other lengths are available on request
- Available in Stainless steel

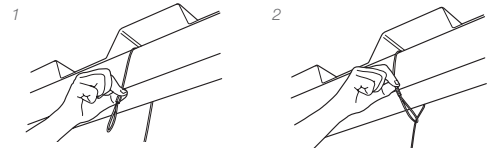

Stud

- Ideal for anchoring into concrete ceilings, metal decking and channel nuts
- Available in M6, M8 and M10, up to 225 kg SWL, with a 5:1 safety factor
- Supplied with drop-in anchors (as standard) or nuts as required
- Comes as a ready-to-use kit with wire rope and a Gripple hanger
- Available in lengths from 1 m to 10 m
- Other lengths are available on request
- Available in Stainless steel

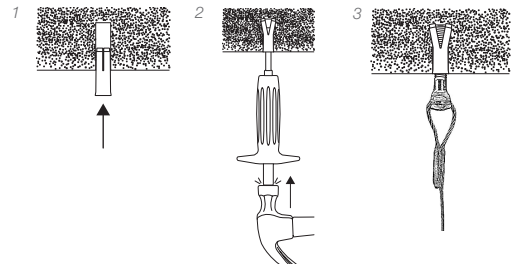

Toggle

- Ideal for roof cladding, light fittings, luminaires and other cavities
- Available up to 90 kg SWL, with a 5:1 safety factor
- Comes as a ready-to-use kit with wire rope and a Gripple hanger
- Available in lengths from 1 m to 10 m
- Other lengths are available on request
- Available in Stainless steel

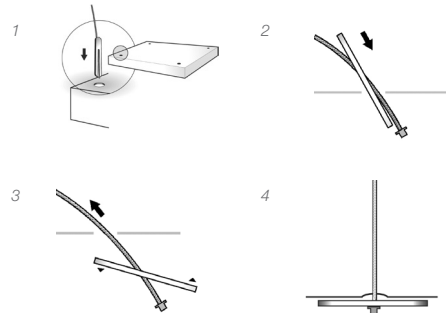

Snap hook

- Quick and easy attachment to cable basket, purlin clips and light fittings
- Available up to 90 kg SWL, with a 5:1 safety factor
- Comes as a ready-to-use kit with wire rope and a Gripple hanger
- Available in lengths from 1 m to 10 m
- Other lengths are available on request

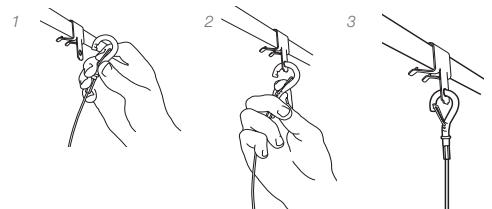

45° Eyelet

- Ideal for use in bracing applications
- Available up to 90 kg SWL, with a 5:1 safety factor
- Comes as a ready-to-use kit with wire rope and a Gripple hanger

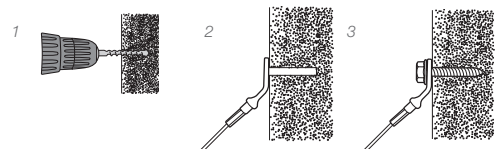

GMD60 Wedge

Ideal for the suspension of services from SMD TR60 and TR80 decking composite floor decking

Features & Benefits

- Adjustable and removable, no need for specialist tools or skills
- Available up to 100 kg SWL, with a 3:1 safety factor
- Comes as a complete kit with wire, Gripple fastener and setting key



Installation

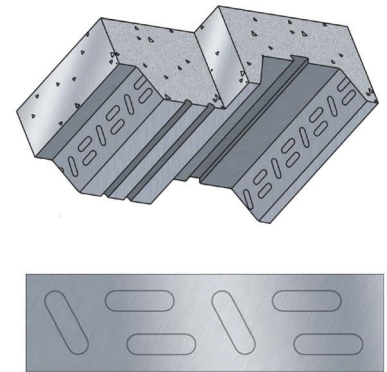
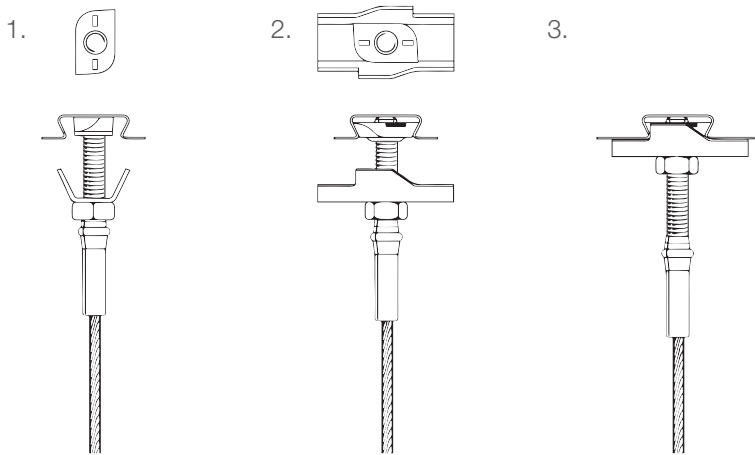

Specification

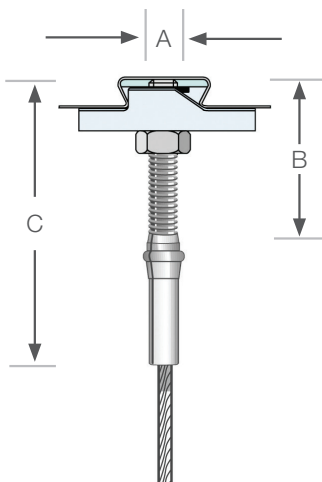

Dimension	mm
A	M8 / M10
B	45
C	70

Submittal Information

Safe Working Load:

Up to 100 kg with a 3:1 safety factor

Swivel Clamp

Strong and versatile multi-directional beam clamp for suspension of light components to pitched beams without welding or drilling



Features & Benefits

- Solid fixing to steel construction without the need for welding or drilling
- Multidirectional clamp
- Designed for suspension of light components to pitched beams without welding or drilling
- For use with flange thickness up to 24 mm
- Articulation to 30° sideways, 45° forwards

Installation

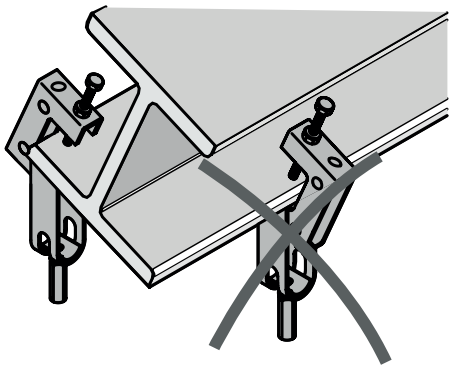

1. Adjust screw to allow space to position onto beam
2. Tighten the screw (M10) to lock in position

When attaching to pitched beams adhere to the recommended safe working load table.

Safe working load table.
Based on 1.4:1 Safety Factor.

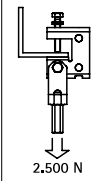
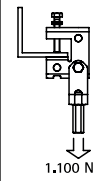
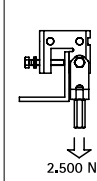
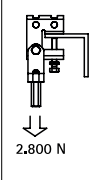
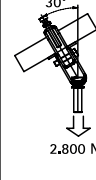
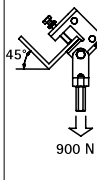
		
2,500 N	1,100 N	2,500 N
		
2,800 N	2,800 N	900 N

Specification

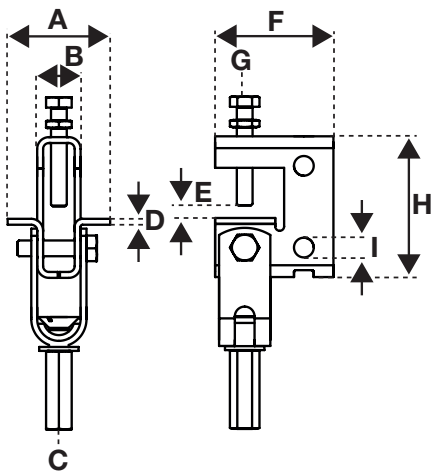

Dimensions (mm)								
A	B	C	D	E	F	G	H	I
52	22	M10	3	24 max.	60	13	72	10

Submittal Information

Safe Working Load:

Up to 285 kg

Use with a No.1, No.2, No.3 or No.4 Gripper hanger

Sprinkler Hanger

Designed to provide vertical support to non-insulated piping systems.



Features & Benefits

- Double thickness mild steel shaped to support the pipe
- Pipe elevation can be altered by adjusting the position of the sprinkler nut on the hanger rod at the top of the hanger
- Suitable for fire extinguishing pipes installations
- Available with and without sprinkler nut
- 3:1 Safety Factor



Available Sizes and Load Ratings

Size	Width (mm)	Thickness (mm)	Hole dia (mm)	Load (kg)
3/4'	16	1.2	11	143
1'	16	1.2	11	143
1.25'	16	1.2	11	143
1.5'	16	1.2	11	143
2'	16	1.2	11	143
2 1/2'	19	1.6	11	304
3'	19	1.6	11	304
3 1/2'	19	1.6	11	304
4'	19	1.6	11	304
5'	25	2	13	571
6'	25	2	13	571
8'	25	2.5	13	714

Technical comparison

	Griptide Clamps	Local Clamps
Load bearing capacity	Properly tested and specified	No details available
Certification	Lloyds approval	No certificate
Thickness	As per details in catalogue	No data available
Design service	Griptide is complete solution provider and can design supports for all MEP services	No design service
Sales support	Sales team available in all Metro cities	Need to buy from local market
Site support	Site team can guide in installation	N/A

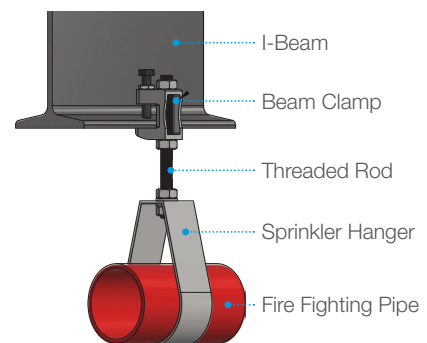
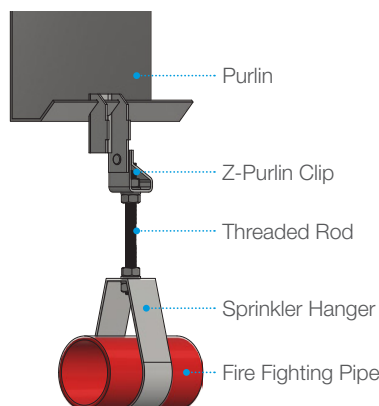
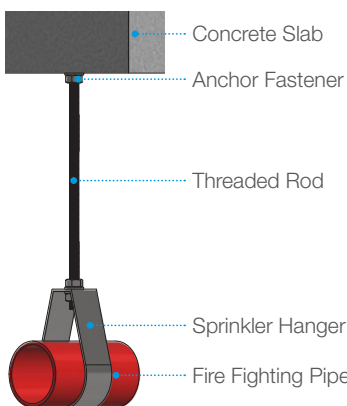

Beam Clamp

A flange clamp suitable for use with parallel or tapered flange beams, supplied with the rear hole drilled or tapped.

Features & Benefits

- Fast installation
- Avoids drilling into I beams
- Good aesthetic appeal
- Common solution for a wide thickness of I beams
- 3:1 Safety Factor
- Safe working loads, M6 and M8 - 110 kg, M10 - 240 kg, M12 - 310 kg, M16 - 520 kg



Installation

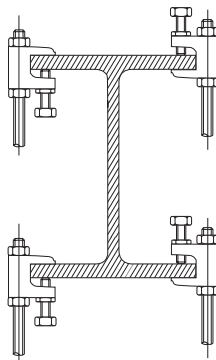

1. Guideline: tighten the setscrew finger tight and then apply a further quarter turn (90°) with spanner.

Specification

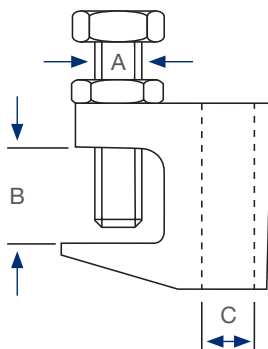

Dimension (mm)	
A	M8/M10/M12
B	3 - 17
C	M8/M10/M12/M16

* Gripple has a policy of ensuring that all of our systems have safe working loads. Please discuss your project requirements with your local Gripple representative who will advise on the technical requirements

Z Purlin Clip

Designed for fixing to purlins to allow fast suspension with wire using a Gripple Stud end fixing.

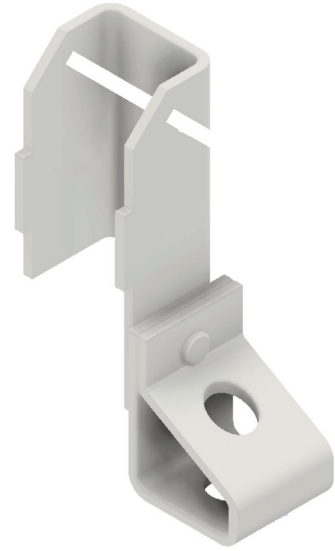

Features & Benefits

- Holds fast at 90°
- For fixing to purlins
- With holder (M8 - M10) for fast suspension using Gripple stud end fixing (adjustable by screwing)
- 1:2 Safety Factor

Installation

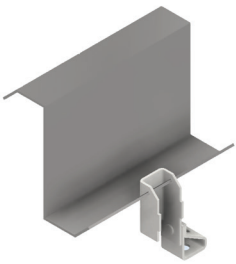

1. Position on purlin and clip into place
2. Insert stud end fixing into holder
3. Adjust by screwing to preferred height

Submittal Information

Safe Working Load:

Up to 45 kg

Material:

Spring Steel

For use with static loads only

Strut Beam Clamp

Fixing to steel beam

Features & Benefits

- For solid fixing to steel construction without the need for welding or drilling
- Always use 2 beam clamps per fixing
- Material: Steel

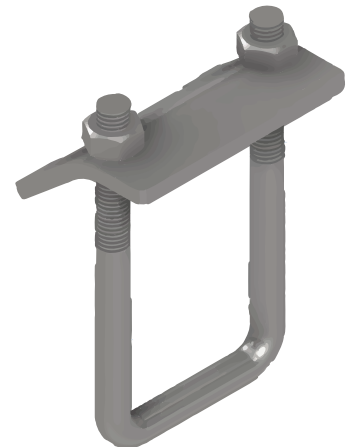

L-Cleat

Versatile connector for various 90 degree and 45-degree connections

Features & Benefits

- For rigid connections at 90 degree or 45 degree channels joints
- Finish- Electro-galvanized or HDG
- Customized solution can be provided based on-site requirement
- Web cleats are also available for heavier loads
- Different models available-
 - L cleats in different sizes from 3 mm to 14 mm thickness
 - Single or double web cleat in 3 mm to 14 mm thickness
 - 45 degree cleats in 4mm to 6mm thickness



Pipe Hanger with EPDM Lining

Designed for hanging non-insulated stationary pipework in a horizontal position. Ideal for supporting pipes along the roof

Features & Benefits

- Strong - mild steel shaped to wrap around the pipe
- Versatile - range of hangers depending on the load to be carried
- Easy - permits installation before and after pipe is in place

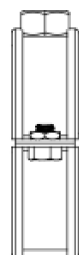
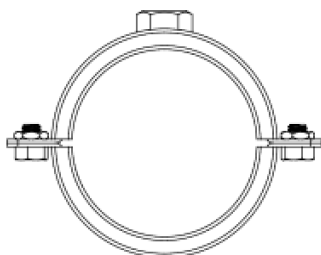

Submittal Information

Load Rating - see table in PI sheet for details

Material - mild steel

Clevis Hanger

Designed to support firefighting pipes running in horizontal direction from ceiling

Features & Benefits

- Clevis hangers are designed to take heavy duty loads
- Removal of complete support is not required in case of maintenance
- Safety factor 5:1



Strut Connector

Ideal Solution to join in-line channels

Features & Benefits

- Ideal solution to join in-line channels
- Quick and easy installation
- Finish- Hot Dip Galvanized/Electro-galvanized



Strut Washer

Ideal for fastening of eyebolts, rods and bolts components mounted on channels.

Features & Benefits

- Gripple Strut washer provides rigid base to fix bolts/rods with strut system
- With its U-shape design, this washer effectively provides proper grip on strut



U Bolt

Heavy duty U-Bolt designed to grip, guide or support plain and insulated pipes



Features & Benefits

- U-BOLTS find application in securing piping to strut system
- Different sizes are available as per requirement
- U bolt with rubber lining and without rubber lining both are available

Foot Support

Ideal solution for ground mounting services

Features & Benefits

- Foot support is non-penetrative support system for ground mounted services
- Multiple services like duct/pipe/cable-tray can be mounted on foots using different accessories
- Provide benefits like saving on time and installation cost
- Improved system aesthetics without penetrating the roof top
- Standard foot size available- 300mm*300mm
- Safe working load-350Kg
- Safety Factor- 5:1



Installation

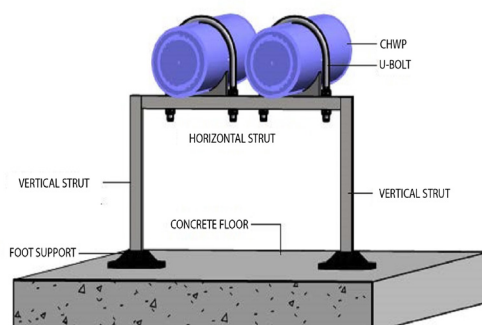

Material

Foot-

UV stabilized Nylon with glass filled

Strut-

41x41x2.5 Hot Dip Galvanized

U Strap

The standard Pipe Strap is crafted from mild steel and designed in a shape that securely holds the pipe in place against walls or strut channels

Features & Benefits

- A standard pipe strap is suitable for providing support to a piping system with fittings on walls or strut channels

Size available- 20 mm to 200 mm

Material- Mild Steel

Finish- Electro-galvanized/ Hot-dip galvanized



Wall Bracket

Ideal solution to connect strut system with wall or ceiling

Features & Benefits

- Ideal solution to create cantilever arrangement from wall
- Ideal solution to support struts as vertical member in heavy duty supports
- Quick and easy installation
- No Drilling and welding required in channels
- Customized solutions can be available as per site conditions
- Finish- Hot Dip Galvanized/Electro-galvanized
- Material Different sizes available for 41x21, 41x41, 41x62 and 41x82 channel size



Conduits Run Clips

For flange up 2 - 7 mm

Features & Benefits

- For quick fixing of cables
- For Static Loading Only
- 2-4mm & 4-7mm Variants
- Material: Spring Steel (type CS70)
- Surface treatment: Delta-Tone 9000 (480 hours)

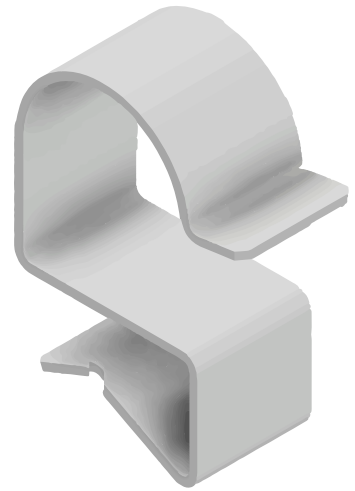

Installation

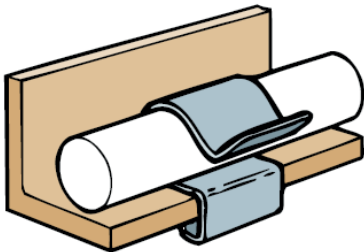

Specification

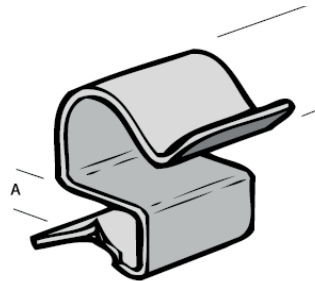

Stiffener Channel and Clamps

Gripple stiffener channel and clamp system are accurately and carefully manufactured to strengthen rod.



Stiffener Clamp assy

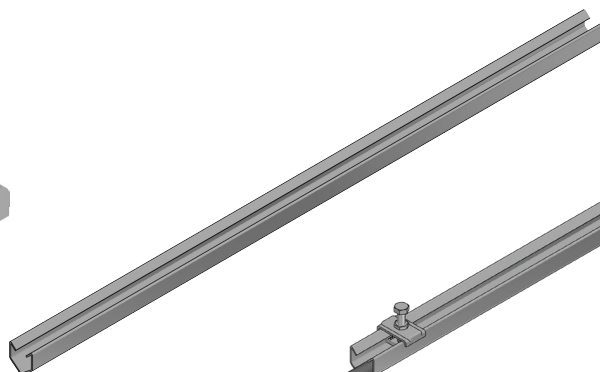

Threaded Rod Stiffener

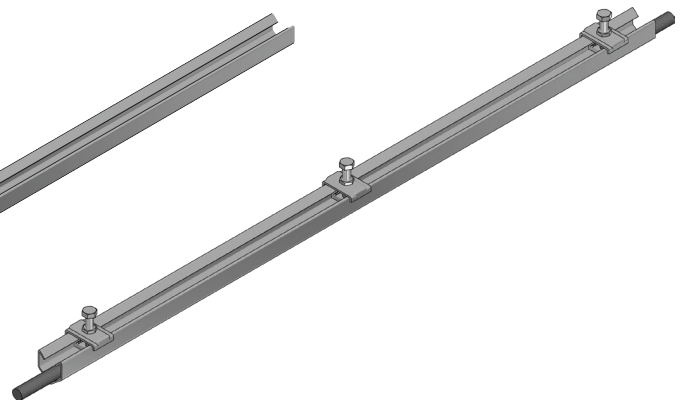

Threaded Rod Stiffener with clamp assy

Accessories

A wide variety of accessories are available, which are specifically designed to suit different substrates on-site.

Concrete

- 1) Drop-in anchor
- 2) Concrete ceiling anchor
- 3) Cracked concrete ring anchor



Beams and purlins

- 1) Tiger clip
- 2) Vertical flange clip
- 3) Purlin clip
- 4) Z purlin clip
- 5) Beam clip
- 6) GF Bracket

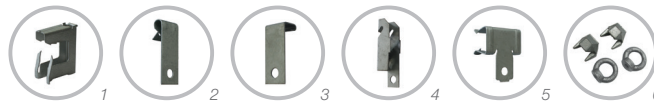

Adaptors

- 1) LSK Clip
- 2) V-Bracket (side)
- 3) V-Bracket (front)
- 4) Spring clip
- 5) M6 and M8 Adaptor
- 6) M8 Decking adaptor
- 7) Turnbuckle
- 8) Eyebolt

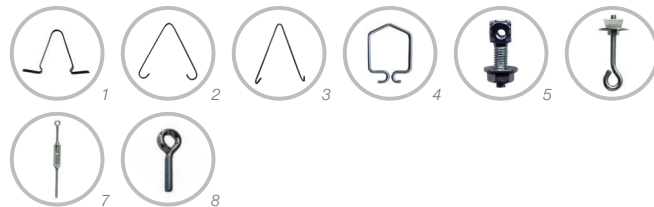

Brackets and attachments

- 1) G-Bracket
- 2) Trapeze
- 3) Trapeze washer
- 4) Link hook
- 5) Karabiner
- 6) U clamp
- 7) Straight connector
- 8) 90 degree connector
- 9) H bracket
- 10) V bracket
- 11) Straight connector



Tools

- 1) Torq tensioning tool
- 2) Adjustment key (small)
- 3) Adjustment key (large)
- 4) Wire cutters (small)
- 5) Wire cutters (large)
- 6) Drop-in anchor punch
- 7) Mechanical setting tool (Drop-in anchor)
- 8) Driver bit

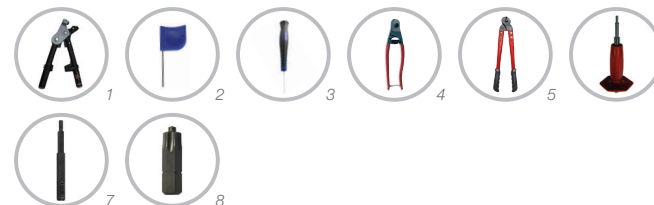

Finishing accessories

- 1) Ceiling fixing kit
- 2) Decor cover
- 3) Corner saddle
- 4) Twister
- 5) Protective sleeving



About Gripple

An introduction

Gripple introduced emphatic change to the building services market in the late 1990s, with a fresh and alternative means of suspension. When the original Gripple device was conceived, as a solution for joining and tensioning fence wires, no-one could have predicted that this would lead to the radical approach of using wire rope hangers, which have fast become the benchmark, for quick and easy methods of hanging mechanical, electrical, HVAC and plumbing services.

As a result of this revolution, Gripple introduced an entirely new way of working to the industrial sector; load-rated hanger kits quickly proved perfect for ducting, cable containment, lighting, piping, false ceilings, signage and much, much more. Driven by a problem-solving attitude and determination to innovate, the product range has expanded to thousands, offering customers a vast array of revolutionary suspension methods.

Not only have Gripple's versatile products brought speed, improved site safety and best practice efficiency savings to the installation process, the company also prides itself on providing bespoke hanging solutions and next day site delivery. Furthermore, personal consultations are always available, and Gripple strives continually to provide the best resolutions for specific needs. As a consequence, the company's capabilities are now recognised, admired and trusted worldwide.



Inside the Old West Gun Works



Improved Gripple housings

“...the company's capabilities are now recognised, admired and trusted worldwide.”

Sustainable development

A commitment to the environment

Gripple has always appreciated the importance of sustainability, pledging in an environmental policy statement to identify risks, prevent pollution, comply with the relevant legislation and improve its environmental performance overall. Customers can be confident that the company has minimised, as far as possible, its environmental impact during product design and manufacture, and believe that they and their applications can play a fundamental part in achieving their own sustainability objectives.

Gripple products have reduced significantly the quantity of steel used on a given project. By replacing traditional threaded rod installations with Gripple hangers, steel consumption is reduced by up to 95%. In other words, for each tonne of rod used, Gripple wire rope hangers can achieve the same results, but potentially weigh as little as 50 kg. Moreover, fewer vehicle movements mean lower transportation costs and emissions and, because they are lighter and easier to carry, accidents during handling and installation are also reduced.

As a manufacturer, Gripple recognises its responsibility to minimise the company's impact on the planet. Therefore, we constantly maximise our energy efficiency, decrease electricity use, reduce landfill / incinerated waste, increase recycling, conserve our raw materials' use and minimise packaging. We also integrate sustainability into our design process, which is epitomised by the impressive fact that a Gripple hanger today uses 30% less zinc than the original design, without compromising its strength or functionality.

A global family

From Sheffield to the wider world

An extensive range of innovative products is produced in state-of-the-art facilities in Sheffield, a city with a rich manufacturing history. On sites in the city's Don Valley - The Old West Gun Works, a former gun barrel plant, and the modern, purpose-built Riverside - this tradition is maintained to reflect the strong heritage that characterises the city.

The company's enviable growth has also demanded the establishment of other company 'homes'. Gripple Europe's base nestles in the Alsace region of France, the US division, Gripple Inc, operates out of Chicago and Gripple India in New Delhi. Firm relationships are maintained with many distributors, to whom Gripple products are supplied to ship to construction sites around the world.

Gripple's core ethos and values permeate each of the company's employees, who work as a team to ensure that the highest quality goods are delivered to all destinations, at all times. A spirit of creativity and innovation has allowed Gripple to reach where it is today and, by keeping this alive, game-changing solutions will continue to be provided far into the future.



*The Old West Gun Works,
Sheffield, UK*



*Gripple Europe SARL,
Obernai, France*



Gripple Inc, Aurora, USA

Awards



*Hugh Facey Gripple's owner
receiving the Queen's Award for
Enterprise - International Business
from the Lord Lieutenant of
South Yorkshire*



- 2020 - "Made in Sheffield" - Overall Winner
- 2019 - UK Employee Ownership Awards- EO Culture
- 2018 - Sagaret Election des Produits du BTP- Innovation Award for Fast Trak
- 2017 - Plastics Industry Awards- Industrial Product Design of the Year
- 2016 - Queen's Award for International Trade
- 2015 - Employee Owned Business of the Year
- 2014 - "Made in Sheffield" - The Investment in People Award
- 2013 - "Made in Sheffield" - Overall Winner
- 2013 - "Make it in Great Britain" - One of the top 25 UK innovative companies as selected by the UK Government
- 2012 - Queen's Award for Enterprise - Innovation
- 2010 - Queen's Award for Sustainable Development
- 2009 - BFA - Innovation Award
- 2009 - BFA - Best Small Company Award
- 2009 - BFA - Best Engineering Plant Award
- 2009 - IMechE - Best Small / Medium Enterprise
- 2008 - Queen's Award for Enterprise - International Business
- 2007 - British Chambers of Commerce - Achievement in International Business
- 2007 - EEF - Annual Environmental Award
- 2006 - The Manufacturer - Manufacturer of the Year Award
- 2004 - IMechE - Best Small / Medium Enterprise
- 2004 - IMechE - Best Factory Award - Overall Winner
- 2004 - National Community Mark Standard
- 2003 - Management Today Awards for Manufacturing - Best Small Plant
- 2003 - Management Today Awards for Manufacturing - Best Innovation for R&D
- 2003 - IMechE - Best Product Innovation
- 2002 - British Chambers of Commerce - Export Excellence Award
- 2001 - National Language for Export - Regional Winner (Trade Partners UK)
- 2000 - Queen's Award for Enterprise - Innovation

National and global projects

India

Airport projects

- Pune Airport
- Bangalore International Airport T2
- Lucknow Airport
- Delhi Airport T3
- Mumbai International Airport
- Chennai Airport T2
- Cochin Airport
- Belgaum Airport
- Vizag Airport
- Guwahati Airport

Government Projects

- Siri Fort Sports Complex, New Delhi – DDA
- Election commission office, Dwarka- CPWD
- Indira Gandhi hospital- PWD
- Redevelopment of Pragati Maidan- NBCC
- NBCC Kidwai Nagar New Delhi
- NBCC SPG, Dwarka
- Boeing Hanger Bay, Nagpur
- Hindon Airbase, Ghaziabad
- MCD IT Civic Centre - CPWD
- Manekshaw Army Mess, New Delhi.
- CAG Jaipur - CPWD
- ONGC, Delhi
- Lady Hardinge Hospital, New Delhi
- Powergrid Corporation, Gurgaon
- Tata Power, Noida
- Power Grid Corporation, Gurgaon
- Bhabha Atomic, Chennai.
- PMI, NTPC
- Safdarjung Hospital, New Delhi
- EIL, Gurgaon
- DDA Dwarka sector
- AIIMS Deogarh
- AIIMS Bilaspur

Pharmaceutical Projects

- Abbott - Bharuch
- Torrent - Baddi
- Torrent - Gujarat
- Teva - Gujarat
- Nitin Life Sciences - Paunta Sahib
- Dr. Reddy's - Ghaziabad
- Dr. Reddy's - Hyderabad
- Sun Pharma - Halol
- Intas - Gujarat
- Ranbaxy - Baddi
- ACG - Gujarat
- Apotex - Bangalore
- Rexum Pharma - Bangalore
- Biocon - Bangalore

Textile Projects

- Trident - Bhopal
- Trident – Budhni
- Seeds - Vizag
- Quantum Clothing - Vizag
- Shahi Exports - Faridabad
- SRF - Chennai
- Ocean India - Vizag
- Brandix - Vizag
- Winsome Textiles - Baddi
- Arvind Mills - Santej
- Garg Acrylics – Bathinda
- Welspun - Vapi

Hotel Projects

- MB Hotel - Faridabad
- Ritz Carlton - Bangalore
- Ibis Hotel – Chennai
- Park Plaza - Zirakhpur
- Hyatt - Manesar
- Bharti Hotel, Aerocity – New Delhi
- Pride Hotel, Aerocity – New Delhi
- Duet Hotel - Chennai
- JRRCL - Jaipur
- Marriott - Guwahati
- Marriott - Shillong
- Royal Plaza - Chennai
- The Claridges - New Delhi
- Taj Palace - New Delhi
- Marriott- Goa

Commercial & Residential Projects

- DLF Capital Greens - Delhi
- GYS Vision - Gurgaon
- Ireo Rise – Mohali
- Emaar MGF Palm Drive - Gurgaon
- MGF Da Villas - Gurgaon
- DLF Mall of India - Noida
- Adobe - Noida
- SAP Lab - Gurgaon
- Infosys - Various Locations
- DLF Crest – Gurgaon
- DLF Camellias – Gurgaon
- NBCC Kidvai Nagar – Delhi
- HCL - Chennai
- HP - Bangalore
- World Bank - New Delhi
- Sun TV - Chennai
- EIL - Gurgaon
- NIIT - Neemrana
- American Express - Gurgaon
- Shiv Nadar University - Dadri
- Success Tower - Gurgaon
- Convergys - Gurgaon
- QAI - Noida
- ONGC - New Delhi
- CISCO - Bangalore
- Deloitte - Mumbai
- IKEA- Bangalore
- IKEA- Hyderabad
- Multiple M3M projects in Gurgaon
- Surat Diamond Bourse -Surat

Industrial Projects

- Knorr Bremse - Palwal
- Maruti-Suzuki – Gurgaon, Manesar
- Yamaha - Greater Noida
- Denso - Jhajjar
- Mann-Hummel - Bawal
- TVS WABCO - Chennai
- Ford – Chennai, Sanand
- Parker Hannifin - Mumbai
- SRF - Chennai
- Fiat – Pune
- Motherson Sumi – Lucknow, Pathredi
- TATA Lockheed Martin Aerostructures - Hyderabad
- Apollo Tyres - Chennai, Vadodara
- MRF Tyres - Chennai
- Pepsi Neelamangala - Satariya
- Coca Cola, Bangalore - Koshi
- SKF – Haridwar, Ahmedabad
- Parker Hannifin - Mumbai
- Volkswagen - Chennai
- BMW - Chennai
- Daimler – Chennai
- JCB - Jaipur
- FKIL - Pune
- Hero Moto Corp - Neemrana, Haridwar Jaipur
- Honda Motors - Tapukara
- Rexam - Chennai
- Honeywell - Pune
- Volvo - Indore
- Tata Cummins, Phaltan - Pune
- ITC – Haridwar, Nepal, Ranjangaon, Kidderpore, Malur
- TBK - Mysore
- ACG - Pitampur
- Panasonic - Jhajjar
- AISIN - Rohtak
- Nokia – Chennai

North America

- MGM City Center, Las Vegas, NV
- Dallas Cowboys Stadium, TX
- Trump Tower, Chicago, IL
- Busch Stadium, St. Louis, MO
- Facebook Data Center, OR
- Walter Reed Medical Center, Washington DC
- Washington Nationals Stadium, DC
- Fort Lee Army Base, Petersburg, VA
- New York Yankees Stadium, NY
- Nestle Plant, Anderson, IN
- Golden Nugget Hotel Casino, Las Vegas, NV
- Calgary Airport, Calgary, AB
- Niagara Regional Hospital, St. Catharines, ON
- Department of Natural Defense, Ottawa, ON
- GM Plant, Toronto, ON
- Wayne Gretzky Sports Centre, Brantford, ON
- Toyota Plant, Woodstock, ON

South America

- Caixa Economica Federal, São Paulo, Brazil
- Fabrica KRAFT, Pernambuco, Brazil
- Prédio Infinity, São Paulo, Brazil
- Lojas Besni, Mogi das Cruzes, São Paulo, Brazil
- ExpoCenter Transamerica, São Paulo, Brazil
- Hyundai CAO, Ribeirão Preto, Brazil
- Shopping Rio Mar, Recife, Brazil
- Loja TAM, Londrina, Brazil
- Hewlett Packard, Guadalajara, Mexico
- Expo Guadalajara, Guadalajara, Mexico
- Soriana Supermarket, Mexico
- Aeropuerto Benito Juarez, Mexico City, Mexico
- Nextel Maintenance Centre, Mexico City, Mexico
- Acero Sueco Palme - Centro de Distribución, c
- El Salto, Mexico
- Centra de Autobuses Tamazula, Mexico
- Convermex, Monterrey, Mexico
- Vega Monumental, Concepción, Chile
- Centro de Distribución Mannheim, Ciudad de los Valles, Chile

Europe

- Wembley Stadium, London, UK
- Swiss Re, London, UK
- Queen Elizabeth Hospital, UK
- RAF, Coningsby, UK
- Next Distribution Centre, UK
- Centre Pompidou (Paris et Metz), France
- Ikea, Auchan, Carrefour, Décathlon, France
- Usines assemblage Airbus A380 & A350 (Toulouse), France
- Direction Générale de la Gendarmerie Nationale (Issy-les-Moulineaux), France
- Musée de la Grande Guerre (Meaux), France
- Commerzbank Arena Frankfurt, Germany
- BMW, Audi, Daimler, Germany
- American Express Verwaltung, Germany
- Deutsche Post Verteilerzentren, Germany
- Netto, Metro, Germany
- Stadler Hannover, Germany

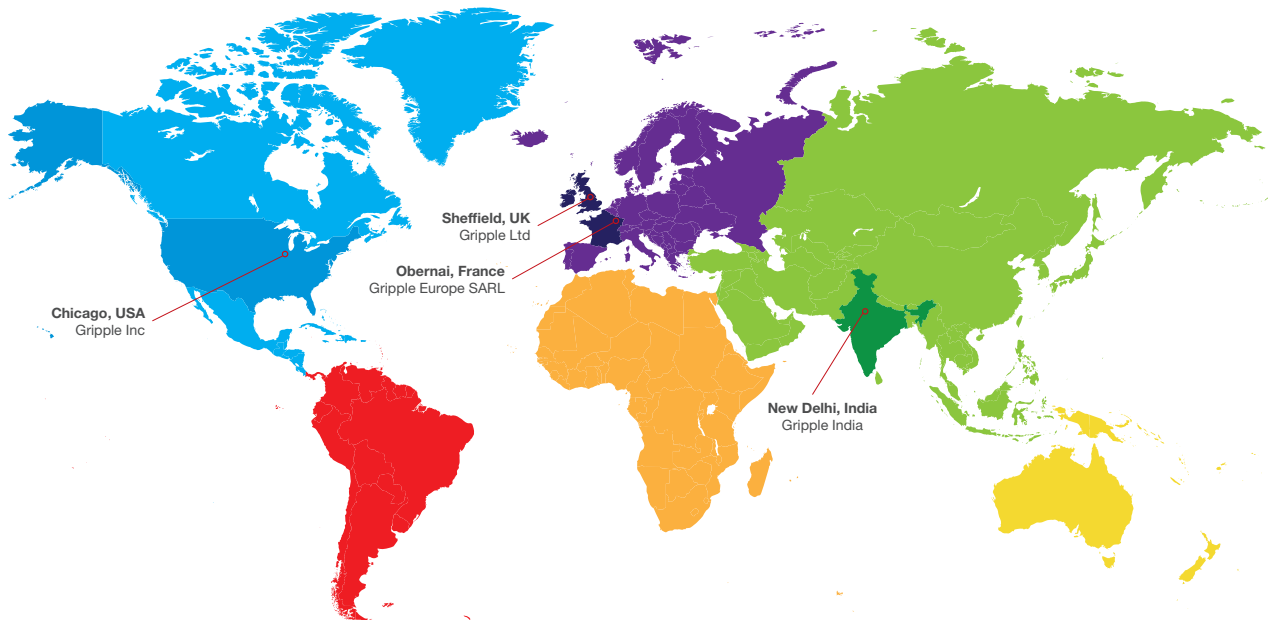

Key Recommendations

Failure to comply with these recommendations may result in product malfunction and possible damage to property or person and will invalidate the Gripple guarantee. Gripple products are guaranteed to be free from defects in materials and workmanship in accordance with our terms and conditions. No other warranty, whether express or implied, including any warranty of merchantability or fitness for purpose shall exist in connection with the sale or use of any Gripple product.

Full technical information and installation instructions should be obtained directly from any regional Gripple office, or via the website www.gripple.com.

Please adhere to the following key recommendations:



Loads

Always operate the product within its stated safe working load range.



Lifting

Do not use for lifting, either by crane or as part of a pulley system. Suspend static loads only.



Installation

Do not walk or stand on the Gripple product installation unless expressly designed for this purpose.



Painting

Painting the hanger is not recommended. In case of any special requirement please get in touch with Gripple Representative



Lubrication

Do not apply oil or any other lubricant to the hanger or any other part of the assembly.



Joining

Never join two ends together in-line.



Storage at Site/ Customer Premises

Gripple Hangers and other Gripple products should be stored properly in such a way that it should be dry and clean.



Wire Rope

Always use the fastener supplied and specified wire rope. Never use on coated wire rope or other rope. Trim any damaged filaments with the wire cutter before use.



Environment

Do not use in chlorinated or chemically corrosive atmospheres. Standard hangers are for use in dry and air conditioned environments only. Stainless steel hangers should be considered for high to saturated humid environments after validation by a competent person. Not suitable for Swimming pools.



Impact

If there is potential for impact on the wire rope suspension or suspended services, seek advice from Gripple Ltd. Technical Services prior to installation.



Hanging at an Angle to Vertical

Ensure that the load calculation considers the effect of 'side load'. For example, at an angle of 60° to vertical the SWL is effectively reduced by 50%



Ducting: When installing included angle teardrop hangers on round/spiral ducting or pipes, the final included angle of the assembly should not exceed 60°.



Y-Fit: Legs on Y-Fit not to be installed greater than 60°.



Visual inspection



Visual quality checks in place



Shadowgraph wedge inspection

Notes



www.gripple.com

info@gripple.com



Gripple Ltd (Headquarters)

The Old West Gun Works
Savile Street East
Sheffield S4 7UQ
UK

T | +44 (0) 800 018 4264

F | +44 (0)114 275 1155

E | info@gripple.com

Gripple Inc

1611 Emily Lane
Aurora
IL 60502
USA

T | +1 866 474 7753

F | +1 800 654 0689

E | usinfo@gripple.com

Gripple Europe SARL

1, rue du commerce
BP 37
67211 Obernai Cedex
France

T | +33 (0)3 88 95 44 95

F | +33 (0)3 88 95 08 78

E | frinfo@gripple.com

Gripple India

C-115, G.F.
Naraina Industrial Area
Phase I
New Delhi-110028

T | +91-11-45136817

E | ininfo@gripple.com



A GLIDE company

